

*New production
of insulated panels*

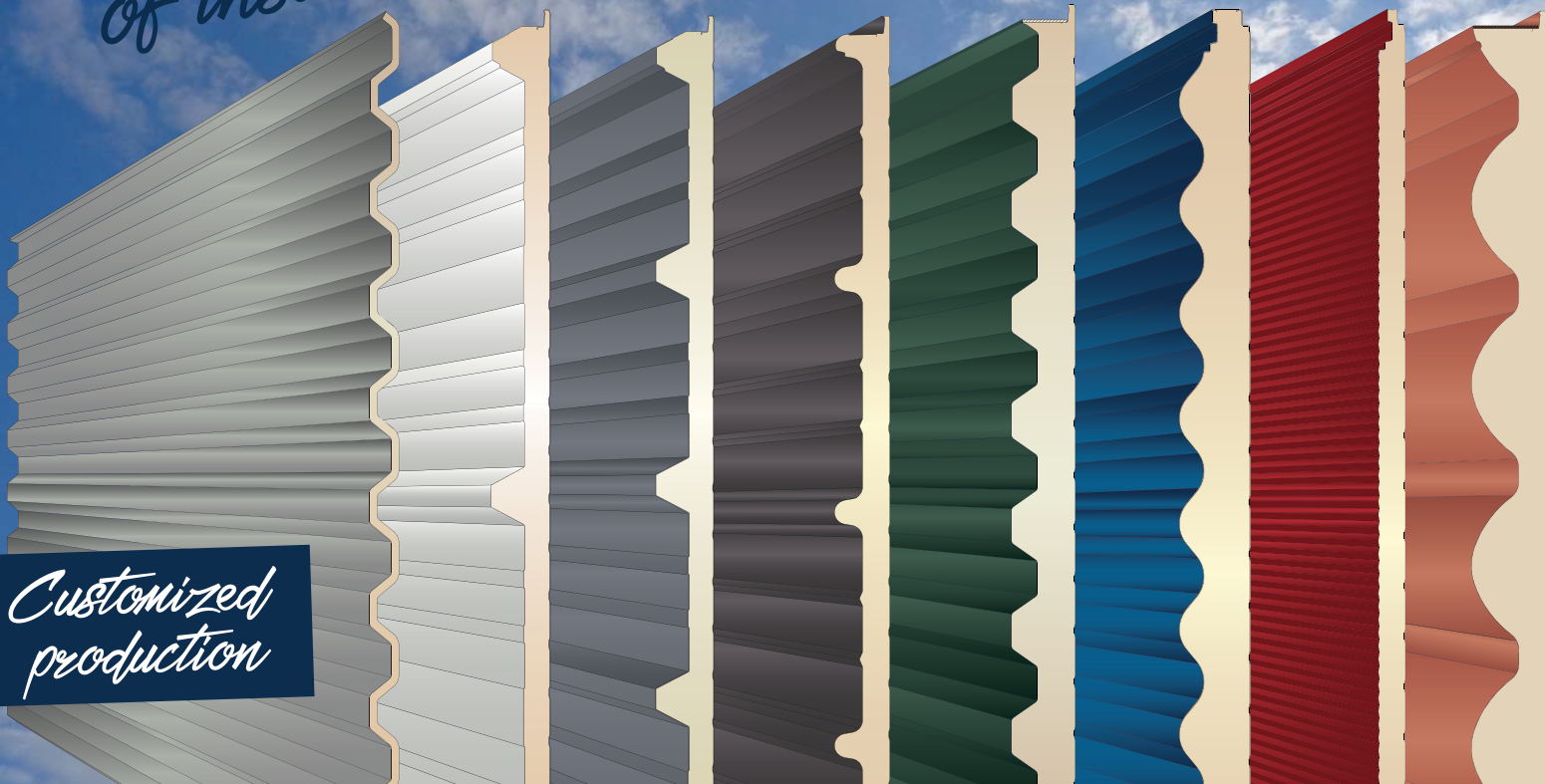

GENERAL CATALOGUE 2018

Façade coverings, roofing, metal slabs, Rheinzink, metal systems and accessories, fixings, smoke vents and insulators.



unimetal.net



Who we are

Unimetal is a company that has been working for years in the sector of metal systems and civil, industrial and agricultural coverings. Continuous researches and studies on the products allowed us to perfect practical and safe systems that guarantee perfect coverings, thus satisfying every need.

Customer care service and technical support for all stages, from design to application. We provide several metal items and equipment according to our customers' specific requests. Bending service and customised profiles for industries on request.

Index



coverings pag.1



Façade coverings pag. 37



Accessories for insulating coverings pag. 45



Metal systems pag. 63



Metal systems accessories pag. 75



Rheinzink pag. 97



PVC pag. 99



Fixings and accessories pag. 101



Equipment pag. 107



Smoke and heat vents,
windows for roofs pag. 111



Storing manual pag. 121

Bending service and customised profiles for industries on request.

Our products



COVERINGS

*New production
Insulated panels*

*Customized
production*



Polyurethane insulated sheets
Polyurethane insulated panels
Eps panels
Corrugated sheets
Undulating sheets
Roofing sheets
Sheets with concealed fixing
10 Perfect covering system
Standing seam coverings
Colour table
Technical specifications scheme
Materials
Table of materials compatibility
Alucopper
Rheinzink

Polyurethane insulated sheets

UNI 28

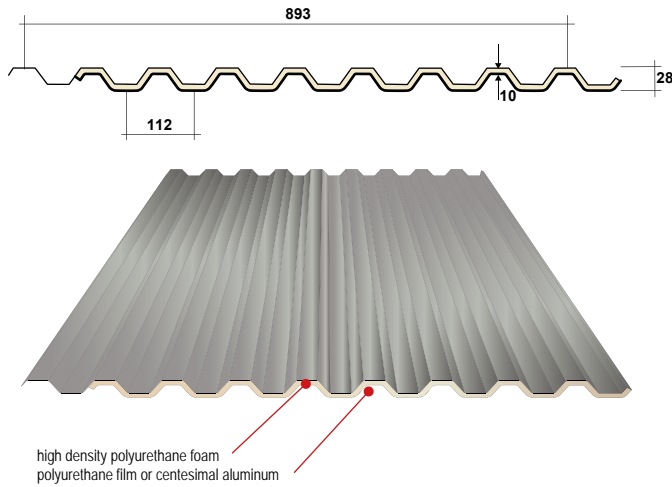

Characteristics

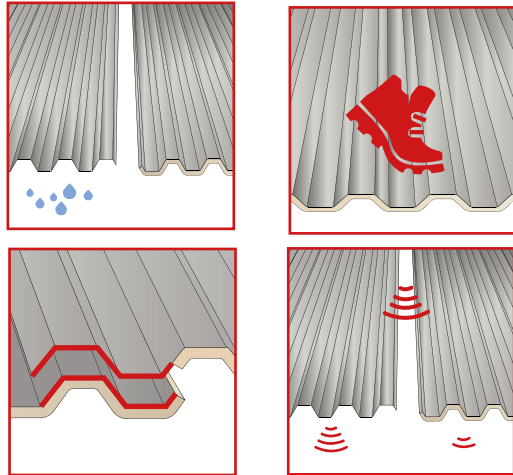

- 1 Noise reduction
- 2 Side overlap of a greek and a half
- 3 Excellent walkability
- 4 Elimination of condensation effect

steel

thickness (mm)	weight (Kg/m ²)	Jxx (cm ⁴ /m)	Wxx (cm ³ /m)
0,50	4,88	7,68	3,58
0,60	5,85	9,22	4,84
0,80	7,81	12,30	7,88



Maximum permissible load in Kg/m²
(including service weight)

thickness (mm)	interaxis cm.								
	100	125	150	175	200	225	250	275	300
0,50	501	321	223	164	126	99	80	66	56
0,60	678	434	301	221	169	134	108	90	75
0,80	1103	706	490	360	276	218	177	146	123

aluminium

thickness (mm)	weight (Kg/m ²)	Jxx (cm ⁴ /m)	Wxx (cm ³ /m)
0,60	2,05	9,22	6,83
0,80	2,73	12,30	9,11

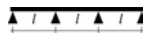

Maximum permissible load in Kg/m²
(including service weight)

thickness (mm)	interaxis cm.				
	100	120	140	160	180
0,60	452	314	231	177	139
0,80	603	419	308	235	186



Polyurethane insulated panels

UNI 3

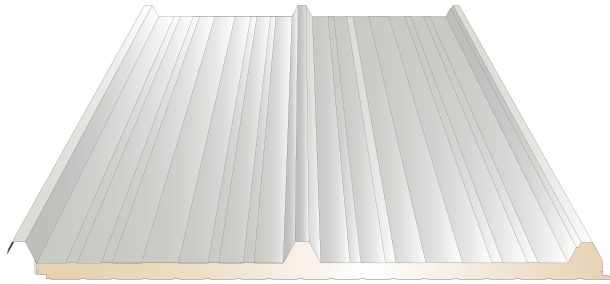
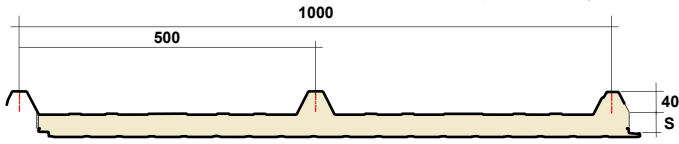

UNI 3

Version available with lower finishes:

- Steel
- Aluminium



steel

upper side
steel 0,4 mm
lower side
steel 0,4 mm

SP	weight	Distance between the bases								U transmittance W/m ² K
		1,50	2,00	2,50	3,00	3,50	4,00	4,50		
30	7,29	190	120	75	45	-	-	-	0,692	
40	7,67	250	160	105	70	-	-	-	0,532	
50	8,05	300	205	140	90	65	-	-	0,432	
60	8,43	340	250	170	120	90	65	-	0,364	
80	9,19	460	340	240	180	135	100	75	0,276	
100	9,95	570	410	320	240	185	140	110	0,223	
120	10,71	670	460	390	300	220	175	140	0,190	

aluminium

upper side
aluminium 0,6 mm
lower side
steel 0,4 mm

SP	weight	Distance between the bases								U transmittance W/m ² K
		1,50	2,00	2,50	3,00	3,50	4,00	4,50		
30	5,87	195	140	95	55	-	-	-	0,692	
40	6,25	255	171	130	85	-	-	-	0,532	
50	6,63	315	230	160	120	85	-	-	0,432	
60	7,01	375	275	195	155	110	80	-	0,364	
80	7,77	495	335	260	210	170	130	95	0,276	
100	8,53	580	420	330	270	225	180	135	0,223	
120	9,29	630	500	390	325	270	230	170	0,190	

UNI 3 Mono

Version available with lower finishes:

- Feltboard
- Centesimal aluminium

UNI 3 Farm

Version available with lower finishes:

- Fiberglass

UNI 5

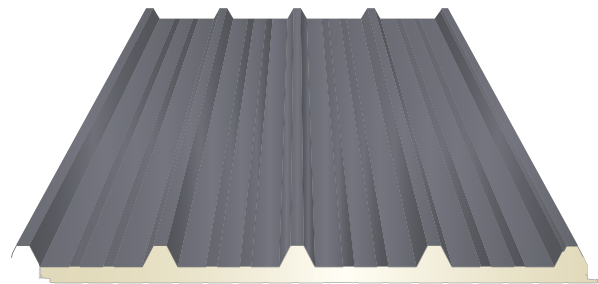
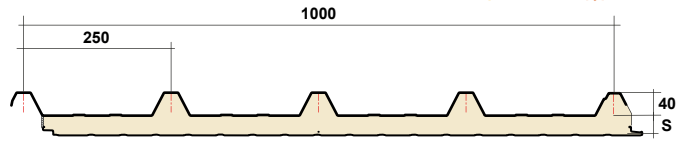

UNI 5

Version available with lower finishes:

- Steel
- Aluminium



steel

upper side
steel 0,4 mm
lower side
steel 0,4 mm

SP	weight	Distance between the bases								U transmittance W/m ² K
		1,50	2,00	2,50	3,00	3,50	4,00	4,50		
30	8,60	255	161	109	78	-	-	-	0,692	
40	8,90	296	196	137	99	73	-	-	0,532	
50	9,40	328	218	160	120	94	68	-	0,432	
60	9,80	357	239	179	141	114	86	62	0,364	
80	10,60	395	279	216	175	146	123	97	0,276	
100	11,40	442	320	255	211	177	153	130	0,223	
120	12,20	484	359	291	244	211	177	153	0,190	

aluminium

upper side
aluminium 0,6 mm
lower side
steel 0,4 mm

SP	weight	Distance between the bases								U transmittance W/m ² K
		1,50	2,00	2,50	3,00	3,50	4,00	4,50		
30	6,60	244	152	104	74	-	-	-	0,692	
40	7,00	276	178	126	93	71	-	-	0,532	
50	7,40	307	204	146	110	86	69	-	0,432	
60	7,80	339	219	159	123	98	80	67	0,364	
80	8,60	372	250	187	149	123	103	87	0,276	
100	9,40	400	279	214	176	147	126	109	0,223	
120	10,20	432	307	243	203	173	149	131	0,190	

UNI 5 Mono

Version available with lower finishes:

- Feltboard
- Centesimal aluminium

UNI 5 Farm

Version available with lower finishes:

- Fiberglass



UNI 1000

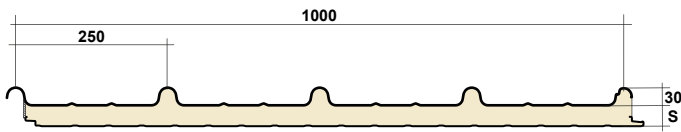

UNI 1000

Version available with lower finishes:

- Steel
- Aluminium



steel

upper side
steel 0,4 mm
lower side
steel 0,4 mm

SP	weight	Distance between the bases							U transmittance W/m ² K
		1,50	2,00	2,50	3,00	3,50	4,00	4,50	
30	8,40	235	140	90	55	-	-	-	0,692
40	8,70	270	175	115	80	53	-	-	0,532
60	9,60	335	215	160	120	95	65	-	0,364

aluminium

upper side
aluminium 0,6 mm
lower side
steel 0,4 mm

SP	weight	Distance between the bases							U transmittance W/m ² K
		1,50	2,00	2,50	3,00	3,50	4,00	4,50	
30	6,40	220	132	85	54	-	-	-	0,692
40	6,80	256	158	106	73	51	-	-	0,532
60	7,60	320	199	138	103	78	60	-	0,364

UNI Roof 28

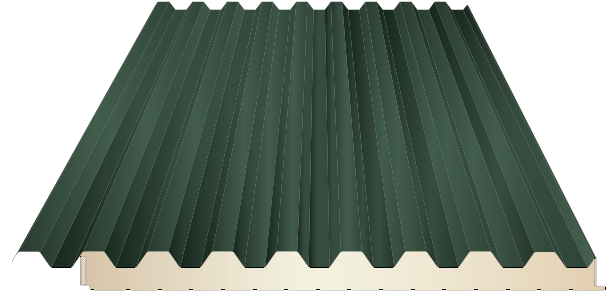
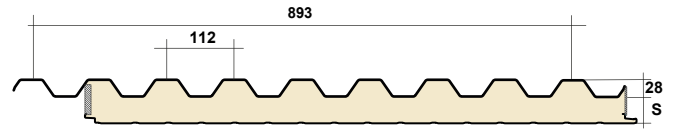

UNI Roof 28

Version available with lower finishes:

- Steel
- Aluminium



steel

upper side
steel 0,5 mm
lower side
steel 0,4 mm

SP	weight	Distance between the bases							U transmittance W/m ² K
		2,00	2,50	3,00	3,50	4,00	4,50	5,00	
40	10,08	376	252	182	134	102	78	60	0,469
80	11,68	633	445	333	258	207	164	135	0,259

aluminium

upper side
aluminium 0,7 mm
lower side
steel 0,4 mm

SP	weight	Distance between the bases							U transmittance W/m ² K
		2,00	2,50	3,00	3,50	4,00	4,50	5,00	
40	7,88	431	282	200	146	109	85	65	0,469
80	9,48	674	471	352	273	216	175	142	0,259

UNI 1000 Mono

Version available with lower finishes:

- Feltboard
- Centesimal aluminum

UNI 1000 Farm

Version available with lower finishes:

- Fiberglass

UNI Roof 28 Mono

Version available with lower finishes:

- Feltboard
- Centesimal aluminum

UNI Roof 28 Farm

Version available with lower finishes:

- Fiberglass



UNI Coppo

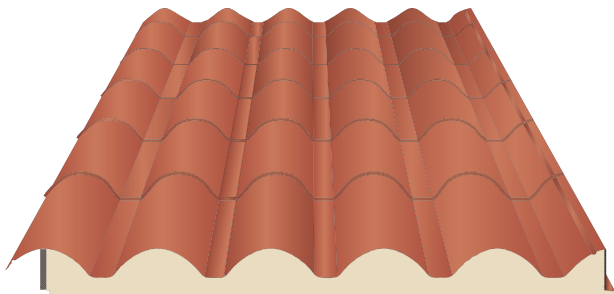
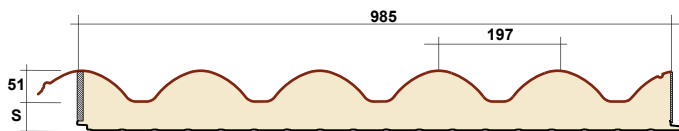

UNI Coppo

Version available with lower finishes:

- Steel
- Aluminium

steel

upper side
steel 0,5 mm
lower side
steel 0,4 mm

SP	weight	Distance between the bases				U transmittance W/m² K
		1,50	2,00	2,50	3,00	
30	10,50	282	175	83	41	0,396
40	10,90	334	195	101	80	0,341
50	11,30	347	208	113	74	0,300
60	11,70	368	220	128	82	0,253
80	12,15	402	255	151	94	0,214
100	13,30	440	283	179	108	0,190

UNI Coppo Mono

Version available with lower finishes:

- Feltboard
- Centesimal aluminum

UNI Coppo Farm

Version available with lower finishes:

- Fiberglass

Available colours - upper side



1 Brick red
2 Antique brick red
3 Dark brown

UNI Wall Concealed fixing

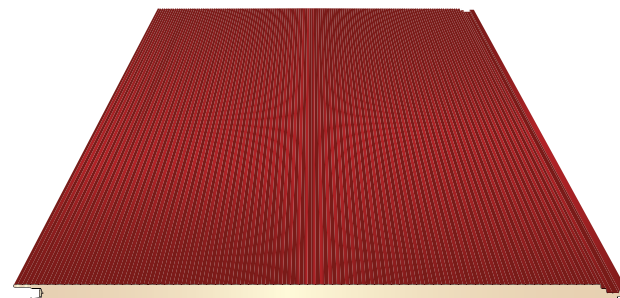
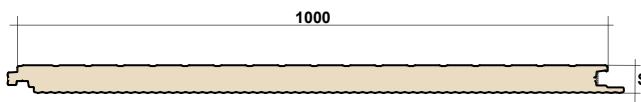

steel

upper side
steel 0,4 mm
lower side
steel 0,4 mm

SP	weight	Distance between the bases						U transmittance W/m² K
		2,00	2,50	3,00	3,50	4,00	4,00	
30	7,06	110	85	65	-	-	0,710	
40	7,42	145	115	90	65	50	0,550	
50	7,81	185	150	115	85	65	0,440	
60	8,20	225	180	140	105	80	0,370	
80	8,98	305	245	190	140	105	0,280	
100	9,76	385	305	240	175	135	0,220	
120	10,54	465	370	290	215	165	0,190	
140	11,20	515	410	320	255	180	0,170	
150	11,71	580	465	365	270	205	0,150	
180	12,88	700	560	440	325	245	0,120	
200	13,66	780	625	490	360	275	0,110	

aluminium

upper side
aluminium 0,6 mm
lower side
aluminium 0,6 mm

SP	weight	Distance between the bases						U transmittance W/m² K
		2,00	2,50	3,00	3,50	4,00	4,00	
30	5,71	120	100	75	-	-	0,710	
40	6,07	160	130	95	75	-	0,550	
50	6,46	200	165	115	90	70	0,440	
60	6,85	240	195	140	105	85	0,370	
80	7,63	320	260	185	140	110	0,280	
100	8,41	400	320	225	170	135	0,220	
120	9,19	480	385	270	205	160	0,190	
140	11,20	530	420	300	220	175	0,170	
150	10,36	595	480	335	250	195	0,150	
180	11,53	715	575	405	300	230	0,120	
200	12,31	780	625	430	315	245	0,110	

Characteristics

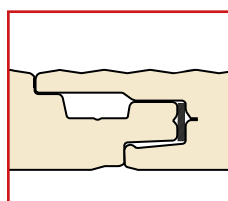

Concealed fixing

Finish available - upper side

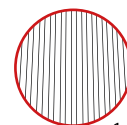

1 diamond



UNI Onda Concealed fixing

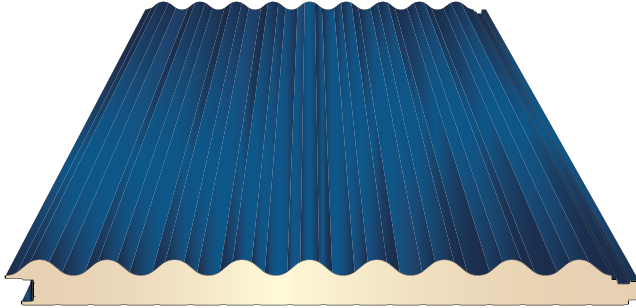
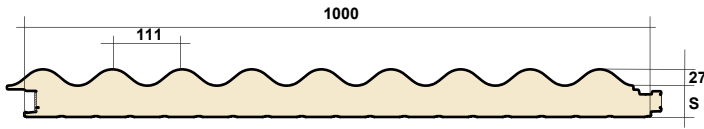

Characteristics

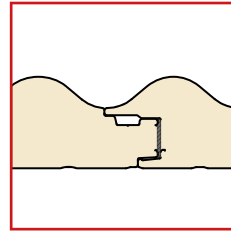

Concealed fixing

steel

upper side
steel 0,5 mm
lower side
steel 0,5 mm

Distance between the bases  U
transmittance

SP	weight	2,00	2,50	3,00	3,50	4,00	4,50	5,00	W/m ² K
50	12,12	246	204	180	153	101	76	48	0,410

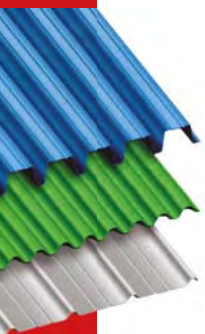

UNI 1000 curved



steel

SP	weight (kg/m ²)	U (W/m ² -K)	A panel (cm ²)	J _{xx} (cm ⁴ /m)	W _{xx} (cm ³ /m)	σ _a (kg/cm ²)
40	9,73	0,588	9,53	49,706	11,495	1400
60	10,53	0,392	9,53	101,536	19,616	1400
80	11,33	0,294	9,53	173,203	28,710	1400
100	12,13	0,235	9,53	264,661	38,407	1400

Rc 350 cm. interaxis m

thickness	SP	2,00	2,50	3,00	3,50	4,00	4,50
0,5/0,5	40	539	414	291	201	142	101
0,5/0,5	60	647	517	414	335	273	204
0,5/0,5	80	727	596	489	404	335	279
0,5/0,5	100	789	660	552	463	389	328

Rc 500 cm. interaxis m

thickness	SP	2,00	2,50	3,00	3,50	4,00	4,50
0,5/0,5	40	421	325	215	147	102	72
0,5/0,5	60	506	403	324	263	216	151
0,5/0,5	80	570	464	381	315	263	221
0,5/0,5	100	623	514	429	360	304	258

Rc 600 cm. interaxis m

thickness	SP	2,00	2,50	3,00	3,50	4,00	4,50
0,5/0,5	40	373	269	180	122	84	58
0,5/0,5	60	452	357	286	232	173	127
0,5/0,5	80	513	413	337	278	232	195
0,5/0,5	100	564	459	380	318	268	228

Rc 1000 cm. interaxis m

thickness	SP	2,00	2,50	3,00	3,50	4,00	4,50
0,5/0,5	40	241	155	100	64	41	26
0,5/0,5	60	361	270	198	138	97	68
0,5/0,5	80	428	322	252	203	166	122
0,5/0,5	100	489	368	291	236	195	163

length MAX 6 mt

variable radius from 3,5 to 20 mt

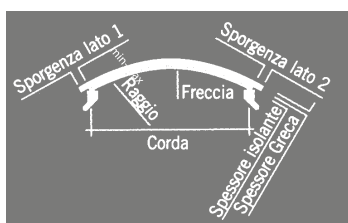

UNI 73 curved

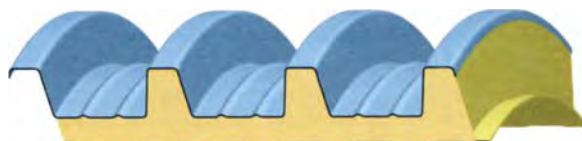

steel

weight (kg/m ²)	A pan. up (cm ²)	J _{xx} (cm ⁴ /m)	W _{xx} (cm ³ /m)	σ _a (kg/cm ²)	f _y (kg/cm ²)
13,61	5,97	224,99	11,432	1100	1610
14,41	5,97	320,90	11,432	1100	1610
15,21	5,97	441,16	11,432	1100	1610
16,01	5,97	585,76	11,432	1100	1610

Rc 350 cm. interaxis m

thickness	SP	2,00	2,50	3,00	3,50	4,00	4,50
0,6/0,5	40	899	673	515	399	313	247
0,6/0,5	60	1309	1015	781	609	480	381
0,6/0,5	80	1413	1187	994	834	662	529
0,6/0,5	100	1497	1277	1086	923	785	669

Rc 500 cm. interaxis m

thickness	SP	2,00	2,50	3,00	3,50	4,00	4,50
0,6/0,5	40	676	506	386	298	232	183
0,6/0,5	60	1007	764	589	459	361	286
0,6/0,5	80	1110	925	774	631	501	401
0,6/0,5	100	1181	996	844	718	613	526

Rc 600 cm. interaxis m

thickness	SP	2,00	2,50	3,00	3,50	4,00	4,50
0,6/0,5	40	576	430	327	251	195	152
0,6/0,5	60	859	652	502	390	306	242
0,6/0,5	80	1000	824	686	538	426	340
0,6/0,5	100	1070	891	750	635	541	464

Rc 1000 cm. interaxis m

thickness	SP	2,00	2,50	3,00	3,50	4,00	4,50
0,6/0,5	40	354	260	193	145	109	82
0,6/0,5	60	537	402	305	234	180	139
0,6/0,5	80	719	548	422	329	257	202
0,6/0,5	100	901	695	543	428	340	271

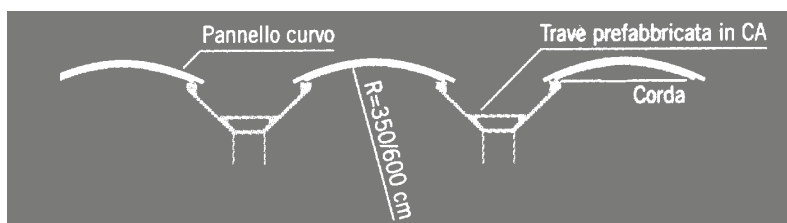

Eps panels

UNI 4000 Eps



self-extinguishing

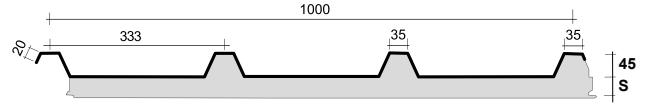

Geometric characteristics

Properties	Units of measurements	Size
Width	mm	1000
Height	mm	size depending on transport possibilities
Panel thickness	mm	40-140

Characteristics

Insulator: Expanded polystyrene panel, synthesised and self-extinguishing
 Density: Eps 100 other densities on request
 Thermal conductivity coefficient: 0,030 with black expanded Eps

Panel technical features

Thickness	Width	U thermal transmittance	Weight
mm	mm	W/ m ² K	kg/m ²
40	1000	0,69	8,38
50	1000	0,67	8,63
60	1000	0,59	8,88
80	1000	0,42	9,38
100	1000	0,28	9,88
120	1000	0,23	10,38
140	1000	0,21	10,88

Uniform load Kg/mq

Distance between the bases



S mm		1,50	2,00	2,50	3,00	3,50	4,00	4,50	5,00	5,50	6,00	6,50	7,00
40	Light (m)	378	334	258	203	157	117	90	66	-	-	-	-
50		399	366	293	259	186	141	111	76	47	-	-	-
60		-	-	364	303	261	204	154	123	91	48	-	-
80		-	-	414	367	314	263	203	162	136	90	44	-
100		-	-	-	389	362	315	263	202	168	132	80	41
120		-	-	-	450	412	360	316	259	212	194	142	90
140		-	-	-	468	420	372	324	268	220	203	153	99

Uniform load Kg/mq

Distance between the bases



S mm		1,50	2,00	2,50	3,00	3,50	4,00	4,50	5,00	5,50	6,00	6,50	7,00
40	Light (m)	391	345	272	216	168	124	99	70	-	-	-	-
50		412	382	301	272	197	149	120	84	52	-	-	-
60		-	-	374	317	279	214	163	129	99	54	-	-
80		-	-	421	378	321	274	213	173	143	96	49	-
100		-	-	-	401	374	326	274	211	175	144	85	47
120		-	-	-	472	422	375	327	270	220	200	152	98
140		-	-	-	493	437	387	348	283	234	210	164	107

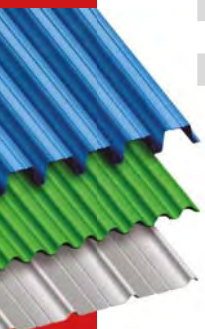

UNI wall Eps



self-extinguishing

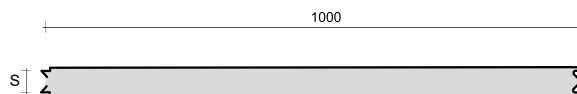

Geometric characteristics

Properties	Units of measurements	Size
Width	mm	1000
Height	mm	size depending on transport possibilities
Panel thickness	mm	40-140

Characteristics

Insulator: Expanded polystyrene panel, synthesised and self-extinguishing
 Density: Eps 100 other densities on request
 Thermal conductivity coefficient: 0,030 with black expanded Eps

Panel technical features

Thickness	Width	U thermal transmittance	Weight
mm	mm	W/ m ² K	kg/m ²
40	1000	0,69	8,23
50	1000	0,67	8,48
60	1000	0,59	8,73
80	1000	0,42	9,23
100	1000	0,28	9,73
120	1000	0,23	10,23
140	1000	0,21	10,73

Uniform load Kg/mq

▲ ▲

Distance between the bases	S mm	1,50	2,00	2,50	3,00	3,50	4,00	4,50	5,00	5,50	6,00
Light (m)	40	378	334	258	203	157	117	90	-	-	-
	50	399	366	293	259	186	141	111	-	-	-
	60	-	-	364	303	261	204	154	49	-	-
	80	-	-	414	367	314	263	203	111	78	-
	100	-	-	-	389	362	315	263	136	91	62
	120	-	-	-	450	412	360	316	162	99	70
	140	-	-	-	468	420	372	324	178	120	78

Uniform load Kg/mq

▲ ▲ ▲ ▲

Distance between the bases	S mm	1,50	2,00	2,50	3,00	3,50	4,00	4,50	5,00	5,50	6,00
Light (m)	40	378	334	258	203	157	117	90	-	-	-
	50	399	366	293	259	186	141	111	-	-	-
	60	-	-	364	303	261	204	154	61	-	-
	80	-	-	414	367	314	263	203	123	89	-
	100	-	-	-	389	362	315	263	150	102	73
	120	-	-	-	450	412	360	316	175	118	81
	140	-	-	-	468	420	372	324	190	137	90



Corrugated sheets

GENUS Coppo

new

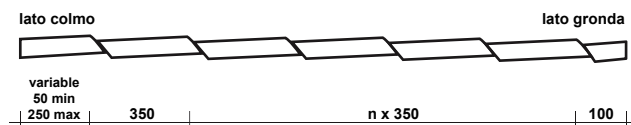
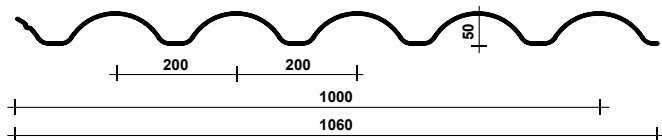

steel

thickness (mm)	weight (Kg/m ²)	Jxx (cm ⁴ /m)	Wxx (cm ³ /m)
0,50	4,91	17,43	6,41
0,60	5,89	21,30	7,81
0,80	7,85	29,04	10,62

aluminium

thickness (mm)	weight (Kg/m ²)	Jxx (cm ⁴ /m)	Wxx (cm ³ /m)
0,70	2,36	24,78	9,08
0,80	2,70	28,66	10,48

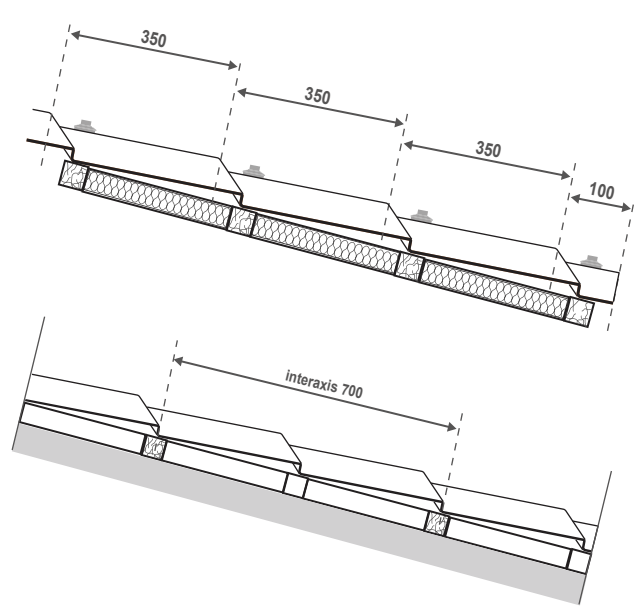

Genus Coppo is a shaped sheet for the roofing of civil buildings, its particular profile allows to satisfy even the aesthetic sense, once laid it has the effect of a real roof tile. The battens must be provided, as for a traditional roof in traditional tiles, every 350mm. In the case of a plane with continuous support, the center distance can be every 700 mm with the use of a suitable compression resistant insulator.

Colours available - upper side



- 1 Brick red
- 2 Antique brick red
- 3 Dark brown

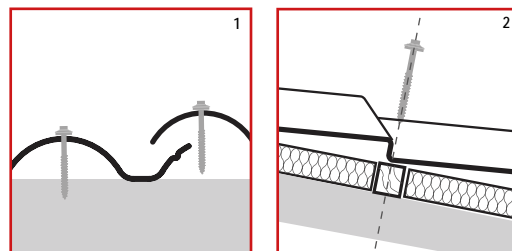

- 1 Overlap half tile
- 2 Fixing screw (min. 35mm)

Also available with anti-condensation felt at lower side

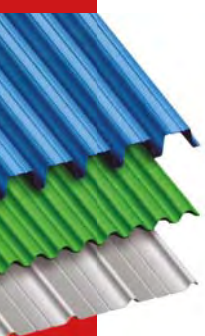

GENUS 1000

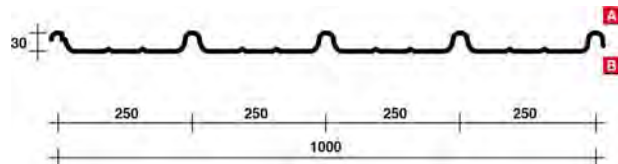

steel

thickness (mm)	weight (Kg/m ²)	Jxx (cm ⁴ /m)	Wxx (cm ³ /m)
0,50	4,71	4,81	1,92
0,60	5,65	4,99	2,00
0,80	7,54	6,74	2,70
1,00	9,42	8,40	3,38



thickness (mm)	interaxis cm.							
	60	80	100	120	150	200	225	275
0,50*	670	377	241	167	104	-	-	-
0,60	695	391	250	174	108	-	-	-
0,80	940	529	338	235	146	61	-	-
1,00	1176	661	423	294	182	77	54	-



Maximum permissible payload Kg/m²
(including service weight)

thickness (mm)	interaxis cm.							
	60	80	100	120	150	200	225	275
0,50*	878	494	316	220	141	79	62	-
0,60	911	512	328	228	146	82	65	-
0,80	1232	693	444	308	197	111	88	59
1,00	1542	867	555	385	247	139	110	73

aluminium

thickness (mm)	weight (Kg/m ²)	Jxx (cm ⁴ /m)	Wxx (cm ³ /m)
0,60	1,95	4,99	2,00
0,70	2,27	5,79	2,32
0,80	2,59	6,63	2,66
1,00	3,24	8,40	3,38



thickness (mm)	interaxis cm.				
	60	80	100	120	150
0,60	171	96	62	-	-
0,70	198	112	71	-	-
0,80	228	128	82	57	-
1,00	289	163	104	72	-

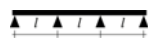

Maximum permissible payload Kg/m²
(including service weight)

thickness (mm)	interaxis cm.				
	60	80	100	120	150
0,60	224	126	81	56	-
0,70		146	94	65	-
0,80	298	168	107	75	-
1,00	379	213	136	95	61



overlap example
1. capillary
2. support base

Note: max deflection
= $f \leq l/150$.
1Kg/m² 10 N/m²
values of loads
implying higher
inflections are
indicated in red.

* CNR 10022/85 norm advises not to use it for coverings



GENUS 2000

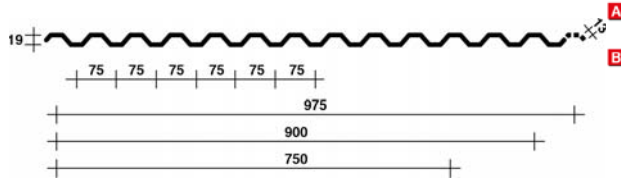

steel

thickness (mm)	weight (Kg/m ²)	Jxx (cm ⁴ /m)	Wxx (cm ³ /m)
0,50	5,23	3,17	3,33
0,60	6,28	3,83	4,02
0,80	8,37	5,11	5,36
1,00	10,47	6,32	6,63

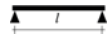

thickness (mm)	interaxis cm.							
	60	80	100	120	150	200	225	275
0,50	1072	452	232	134	69	-	-	-
0,60	1295	546	280	162	83	-	-	-
0,80	1725	728	373	216	110	-	-	-
1,00	2135	901	461	267	137	58	-	-



Maximum permissible payload Kg/m² (including service weight)

thickness (mm)	interaxis cm.							
	60	80	100	120	150	200	225	275
0,50	1520	855	547	335	172	72	51	-
0,60	1836	1033	661	405	207	87	61	-
0,80	2446	1376	880	539	276	116	82	-
1,00	3027	1703	1090	667	342	144	101	55

aluminium

thickness (mm)	weight (Kg/m ²)	Jxx (cm ⁴ /m)	Wxx (cm ³ /m)
0,60	2,16	3,83	4,02
0,70	2,52	4,43	4,64
0,80	2,88	5,04	5,29
1,00	3,60	6,32	6,63

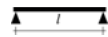

thickness (mm)	interaxis cm.					
	60	80	100	120	150	200
0,60	344	194	103	60	-	-
0,70	397	224	119	69	-	-
0,80	453	255	135	78	-	-
1,00	568	319	170	98	50	-

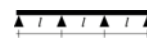

Maximum permissible payload Kg/m² (including service weight)

thickness (mm)	interaxis cm.					
	60	80	100	120	150	200
0,60	451	254	162	113	72	-
0,70	521	293	188	130	83	-
0,80	593	334	214	148	95	-
1,00	744	419	268	186	119	53

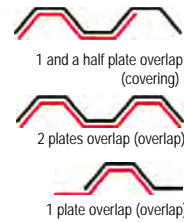

Note: max deflection = $f \leq l/150$.
1Kg/m² 10 N/m² values of loads implying higher inflections are indicated in red.

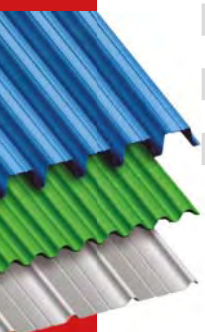

GENUS 900

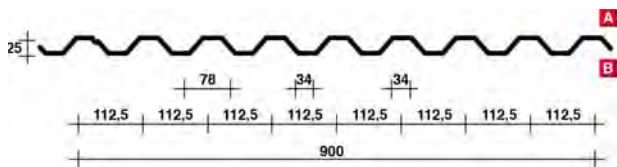

steel

thickness (mm)	weight (Kg/m ²)	Jxx (cm ⁴ /m)	Wxx (cm ³ /m)
0,50	5,23	5,46	4,35
0,60	6,28	6,61	5,27
0,80	8,37	8,86	7,06
1,00	10,47	11,03	8,80

thickness (mm)	interaxis cm.								
	60	80	100	120	150	200	225	275	300
0,50	1515	778	398	230	118	-	-	-	-
0,60	1835	942	482	279	143	60	-	-	-
0,80	2459	1262	646	374	192	81	57	-	-
1,00	3063	1572	805	466	238	101	71	-	-

thickness (mm)	interaxis cm.								
	60	80	100	120	150	200	225	275	300
0,50	1986	1117	715	497	295	124	87	-	-
0,60	2405	1353	866	601	357	151	106	58	-
0,80	3224	1814	1161	806	479	202	142	78	60
1,00	4015	2258	1445	1004	596	252	177	97	75

aluminium

thickness (mm)	weight (Kg/m ²)	Jxx (cm ⁴ /m)	Wxx (cm ³ /m)
0,60	2,16	6,61	5,27
0,70	2,52	7,74	6,17
0,80	2,88	8,86	7,06
1,00	3,60	11,03	8,80

thickness (mm)	interaxis cm.						
	60	80	100	120	150	200	225
0,50	451	254	162	103	53	-	-
0,60	528	297	190	120	62	-	-
0,80	605	340	218	138	71	-	-
1,00	753	424	271	172	88	-	-

thickness (mm)	interaxis cm.						
	60	80	100	120	150	200	225
0,50	591	333	213	148	95	53	-
0,60	693	390	249	173	111	62	-
0,80	793	446	285	198	127	71	52
1,00	987	555	355	247	158	89	65



overlap example
 1. capillary
 2. one wave and a half lateral overlap

GENUS 950/35

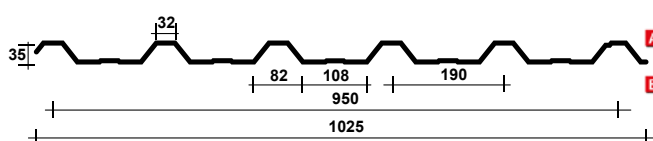

steel

thickness (mm)	weight (Kg/m ²)	Jxx (cm ⁴ /m)	Wxx (cm ³ /m)
0,50	4,96	8,95	4,02
0,60	5,95	10,94	4,91
0,80	7,94	14,94	6,68
1,00	9,92	18,94	8,43

thickness (mm)	interaxis cm.								
	60	80	100	120	150	200	225	275	300
0,50	1401	788	504	350	194	82	57	-	-
0,60	1709	961	615	427	237	100	70	-	-
0,80	2324	1307	837	581	323	136	96	52	-
1,00	2935	1651	1057	734	409	173	121	66	51

thickness (mm)	interaxis cm.								
	60	80	100	120	150	200	225	275	300
0,50	1836	1033	661	459	294	165	131	79	60
0,60	2241	1260	807	560	358	202	159	96	74
0,80	3047	1714	1097	762	487	274	217	131	101
1,00	3848	2165	1385	962	616	346	274	166	128

aluminium

thickness (mm)	weight (Kg/m ²)	Jxx (cm ⁴ /m)	Wxx (cm ³ /m)
0,60	2,05	10,94	4,91
0,70	2,39	12,74	5,71
0,80	2,73	14,74	6,59
1,00	3,41	18,94	8,43

thickness (mm)	interaxis cm.						
	60	80	100	120	150	200	225
0,60	420	236	151	105	67	-	-
0,70	488	275	176	122	78	-	-
0,80	564	317	203	141	90	-	-
1,00	722	406	260	180	115	64	-

thickness (mm)	interaxis cm.						
	60	80	100	120	150	200	225
0,60	551	310	198	138	88	-	-
0,70	640	360	231	160	102	58	-
0,80	739	416	266	185	118	67	53
1,00	946	532	341	237	151	85	67

Note: max deflection = $f \leq l/150$.
 1Kg/m² 10 N/m² values of loads implying higher inflections are indicated in red.



GENUS 800

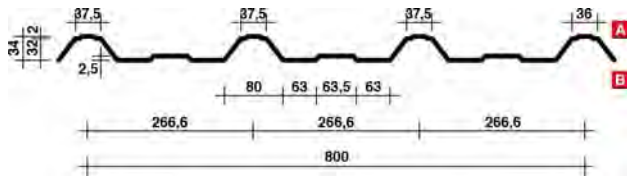

steel

thickness (mm)	weight (Kg/m ²)	Jxx (cm ⁴ /m)	Wxx (cm ³ /m)
0,50	4,91	7,58	3,02
0,60	5,89	9,20	3,67
0,80	7,85	12,37	4,94
1,00	9,81	15,46	6,18

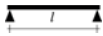

thickness (mm)	interaxis cm.								
	60	80	100	120	150	200	225	275	300
0,50	1050	591	378	262	164	69	-	-	-
0,60	1276	718	459	319	199	84	59	-	-
0,80	1719	967	619	430	267	113	79	-	-
1,00	2153	1211	775	538	334	141	99	54	-

Maximum permissible payload Kg/m² (including service weight)

thickness (mm)	interaxis cm.								
	60	80	100	120	150	200	225	275	300
0,50	1376	774	495	344	220	124	98	66	51
0,60	1673	941	602	418	268	151	119	80	62
0,80	2254	1268	811	564	361	203	160	107	84
1,00	2822	1588	1016	706	452	254	201	134	104

aluminium

thickness (mm)	weight (Kg/m ²)	Jxx (cm ⁴ /m)	Wxx (cm ³ /m)
0,60	2,02	9,20	3,67
0,70	2,36	10,64	4,24
0,80	2,70	12,21	4,88
1,00	3,37	15,46	6,18

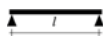

thickness (mm)	interaxis cm.					
	60	80	100	120	150	200
0,60	314	176	113	78	50	-
0,70	363	204	131	91	58	-
0,80	417	235	150	104	67	-
1,00	529	298	191	132	85	-

Maximum permissible payload Kg/m² (including service weight)

thickness (mm)	interaxis cm.					
	60	80	100	120	150	200
0,60	441	231	148	103	66	-
0,70	363	204	131	91	58	-
0,80	547	308	197	137	88	-
1,00	694	390	250	173	111	62



Note: max deflection = $f \leq l/150$. 1Kg/m² 10 N/m² values of loads implying higher inflections are indicated in red.



GENUS 30

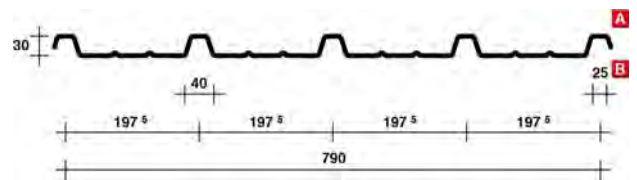

steel

thickness (mm)	weight (Kg/m ²)	Jxx (cm ⁴ /m)	Wxx (cm ³ /m)
0,50	4,97	6,50	2,82
0,60	5,96	7,88	3,42
0,80	7,95	10,58	4,60
1,00	9,94	13,20	5,75

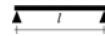

thickness (mm)	interaxis cm.								
	60	80	100	120	150	200	225	275	300
0,50*	980	552	353	245	140	59	-	-	-
0,60	1190	670	428	298	170	72	50	-	-
0,80	1601	901	576	400	229	97	68	-	-
1,00	2002	1126	721	500	285	120	85	-	-

Maximum permissible payload Kg/m² (including service weight)

thickness (mm)	interaxis cm.								
	60	80	100	120	150	200	225	275	300
0,50*	1285	723	463	321	206	116	91	57	-
0,60	1560	878	562	390	250	140	111	69	53
0,80	2099	1181	756	525	336	189	149	93	71
1,00	2624	1476	945	656	420	236	187	116	89

aluminium

thickness (mm)	weight (Kg/m ²)	Jxx (cm ⁴ /m)	Wxx (cm ³ /m)
0,60	2,05	7,88	3,42
0,70	2,39	9,11	3,95
0,80	2,73	10,45	4,54
1,00	3,42	13,20	5,75

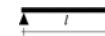

thickness (mm)	interaxis cm.					
	60	80	100	120	150	200
0,60	293	165	105	73	-	-
0,70	338	190	122	85	54	-
0,80	389	219	140	97	62	-
1,00	492	277	177	123	79	-

Maximum permissible payload Kg/m² (including service weight)

thickness (mm)	interaxis cm.					
	60	80	100	120	150	200
0,60	384	216	138	96	61	-
0,70	444	250	160	111	71	-
0,80	510	287	183	127	82	-
1,00	645	363	232	161	103	58

Note: max deflection = $f \leq l/150$. 1Kg/m² 10 N/m² values of loads implying higher inflections are indicated in red.

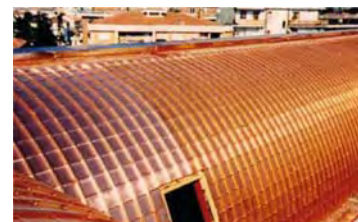

* CNR 10022/85 norm advises not to use it for coverings

GENUS 46



steel

thickness (mm)	weight (Kg/m ²)	Jxx (cm ⁴ /m)	Wxx (cm ³ /m)
0,60	5,89	14,40	3,73
0,80	7,85	17,20	4,40
1,00	9,81	19,80	5,10

thickness (mm)	interaxis cm.								
	100	125	150	175	200	225	250	275	300
0,60	417	267	185	136	104	82	66	55	46
0,80	492	315	219	160	123	97	78	65	54
1,00	571	365	253	186	142	112	91	75	63

thickness (mm)	interaxis cm.								
	100	125	150	175	200	225	250	275	300
0,60	522	334	232	170	130	103	83	69	58
0,80	616	394	273	201	154	121	98	81	68
1,00	714	456	317	233	178	141	114	94	79

Note: max deflection = $f \leq l/150$.
1Kg/m² 10 N/m² values of loads implying higher inflections are indicated in red.



GENUS 45

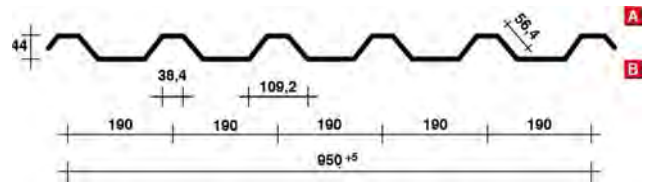

steel

thickness (mm)	weight (Kg/m ²)	Jxx (cm ⁴ /m)	Wxx (cm ³ /m)
0,50	5,16	17,76	6,63
0,60	6,20	21,53	8,04
0,80	8,27	29,08	10,86
1,00	10,34	36,40	13,56

thickness (mm)	interaxis cm.								
	60	80	100	120	150	200	225	275	300
0,50	2307	1297	830	577	369	162	114	62	-
0,60	2798	1574	1007	700	448	196	138	76	58
0,80	3780	2126	1361	945	605	265	186	102	79
1,00	4722	2656	1700	1180	755	332	233	128	98

thickness (mm)	interaxis cm.								
	60	80	100	120	150	200	225	275	300
0,50	3024	1701	1089	756	484	272	215	144	120
0,60	3668	2063	1321	917	587	330	261	175	145
0,80	4956	2788	1784	1239	793	446	352	236	196
1,00	6190	3482	2228	1548	990	557	440	295	246

Note: max deflection = $f \leq l/150$.
1Kg/m² 10 N/m² values of loads implying higher inflections are indicated in red.



GENUS 2007

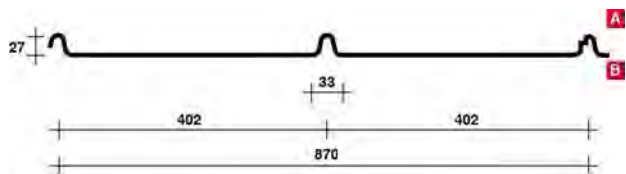

steel

thickness (mm)	weight (Kg/m ²)	Jxx (cm ⁴ /m)	Wxx (cm ³ /m)
0,60	5,41	1,98	0,84
0,80	7,22	2,78	1,14
1,00	9,02	3,49	1,43

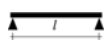

thickness (mm)	interaxis cm.					
0,60	291	164	105	73	-	-
0,80	396	223	143	99	60	-
1,00	499	281	180	125	76	-

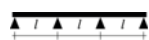

Maximum permissible payload Kg/m²
(including service weight)

thickness (mm)	interaxis cm.					
0,60	382	215	137	95	61	-
0,80	519	292	187	130	83	-
1,00	654	368	235	163	105	59

aluminium

thickness (mm)	weight (Kg/m ²)	Jxx (cm ⁴ /m)	Wxx (cm ³ /m)
0,60	2,17	21,53	8,04
0,70	2,49	24,89	9,27
0,80	2,84	27,15	10,11
1,00	3,55	36,40	13,56

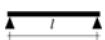

thickness (mm)	interaxis cm.								
0,60	688	387	248	172	110	62	-	-	-
0,70	793	446	286	198	127	71	56	-	-
0,80	865	487	311	216	138	78	62	-	-
1,00	1161	653	418	290	186	104	83	-	-



Maximum permissible payload Kg/m²
(including service weight)

thickness (mm)	interaxis cm.								
0,60	902	507	325	225	144	81	64	-	-
0,70	1040	585	374	260	166	94	74	-	-
0,80	1134	638	408	284	181	102	81	54	-
1,00	1522	856	548	380	244	137	108	72	61

Note: max deflection
= $f \leq l/150$.
1Kg/m² 10 N/m²
values of loads
implying higher
inflections are
indicated in red.

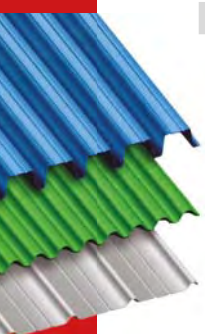

Undulating sheets

these products can be curved

GENUS Onda 18

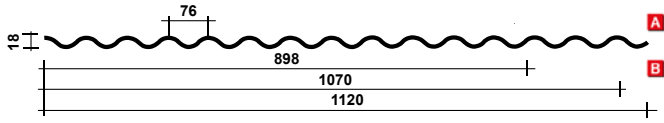

steel

thickness (mm)	weight (Kg/m ²)	Jxx (cm ⁴ /m)	Wxx (cm ³ /m)
0,60	5,64	2,54	2,83
0,80	6,84	3,41	3,79
1,00	9,40	4,26	4,73

thickness (mm)	interaxis cm.						
	60	80	100	120	150	200	225
0,60	860	363	186	107	55	-	-
0,80	1153	487	249	144	74	-	-
1,00	1437	606	310	180	92	-	-

Maximum permissible payload Kg/m² (including service weight)

thickness (mm)	interaxis cm.						
	60	80	100	120	150	200	225
0,60	2149	907	464	269	138	58	-
0,80	2883	1216	623	360	185	78	55
1,00	3593	1516	776	449	230	97	68

aluminium

thickness (mm)	weight (Kg/m ²)	Jxx (cm ⁴ /m)	Wxx (cm ³ /m)
0,70	2,26	2,94	3,27
0,80	2,58	3,37	3,75
1,00	3,23	4,26	4,73

thickness (mm)	interaxis cm.				
	60	80	100	120	150
0,70	280	154	79	-	-
0,80	321	177	91	52	-
1,00	405	223	114	66	-

Maximum permissible payload Kg/m² (including service weight)

thickness (mm)	interaxis cm.				
	60	80	100	120	150
0,70	915	386	198	114	59
0,80	1049	442	227	131	67
1,00	1324	559	286	165	85

Note: max deflection = $f \leq l/150$.
1Kg/m² 10 N/m² values of loads implying higher inflections are indicated in red.



GENUS Onda 27

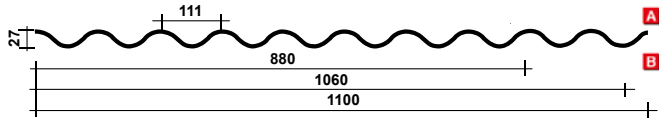

steel

thickness (mm)	weight (Kg/m ²)	Jxx (cm ⁴ /m)	Wxx (cm ³ /m)
0,60	6,00	5,76	4,27
0,80	8,00	7,72	5,72
1,00	10,00	9,62	7,13

thickness (mm)	interaxis cm.								
	60	80	100	120	150	200	225	275	300
0,60	1485	821	420	243	124	53	-	-	-
0,80	1992	1101	564	326	167	70	-	-	-
1,00	2482	1371	702	406	208	88	62	-	-

Maximum permissible payload Kg/m² (including service weight)

thickness (mm)	interaxis cm.								
	60	80	100	120	150	200	225	275	300
0,60	4862	2051	1050	608	311	131	92	51	-
0,80	6522	2752	1409	815	417	176	124	68	52
1,00	8127	3428	1755	1016	520	219	154	84	65

aluminium

thickness (mm)	weight (Kg/m ²)	Jxx (cm ⁴ /m)	Wxx (cm ³ /m)
0,70	2,41	2,94	3,27
0,80	2,75	3,37	3,75
1,00	3,44	4,26	4,73

thickness (mm)	interaxis cm.				
	60	80	100	120	150
0,70	280	154	79	-	-
0,80	321	177	91	52	-
1,00	405	223	114	66	-

Maximum permissible payload Kg/m² (including service weight)

thickness (mm)	interaxis cm.				
	60	80	100	120	150
0,70	915	386	198	114	59
0,80	1049	442	227	131	67
1,00	1324	559	286	165	85

Note: max deflection = $f \leq l/150$.
1Kg/m² 10 N/m² values of loads implying higher inflections are indicated in red.



Coverings

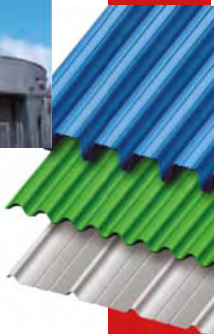

Roofing sheets



GENUS 55

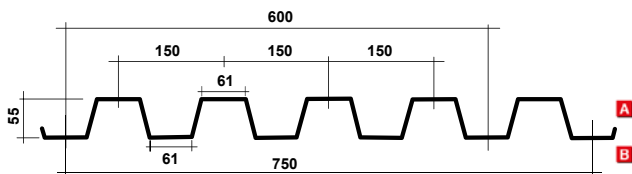

steel

ribbon development 1000: Useful width 600
ribbon development 1250: Useful width 750

thickness (mm)	weight (Kg/m ²)	Jxx (cm ⁴ /m)	Winf (cm ³ /m)	Wsup (cm ³ /m)
0,60	7,85	50,34	16,81	19,43
0,80	10,46	61,01	21,56	24,58
1,00	13,08	72,33	26,44	30,47
1,20	15,70	88,12	31,47	35,87
1,50	19,62	104,2	38,45	42,53



thickness (mm)	interaxis m									Freccia
	1,00	1,50	2,00	2,50	3,00	3,50	4,00	4,50	5,00	
0,60	1183	532	293	184	131	92	69	53	42	F 1/200
				174	99	60	38	25	15	F 1/400
0,80	1903	843	471	296	212	150	115	88	70	F 1/200
				250	142	85	54	35	23	F 1/400
1,00	2601	1157	652	410	284	211	157	119	93	F 1/200
				328	184	117	73	46	31	F 1/400
1,20	3440	1523	823	542	370	269	200	159	125	F 1/200
				421	242	141	90	61	38	F 1/400
1,50	3655	1615	931	632	491	353	276	206	145	F 1/200
				585	401	295	235	175	124	F 1/400



Maximum permissible payload Kg/m²

thickness (mm)	interaxis m									Freccia
	1,00	1,50	2,00	2,50	3,00	3,50	4,00	4,50	5,00	
0,60	1442	655	371	240	165	121	85	72	55	F 1/200
							75	53	35	F 1/400
0,80	2261	1016	580	367	253	183	135	110	86	F 1/200
						174	109	78	54	F 1/400
1,00	3159	1433	811	515	358	260	190	154	120	F 1/200
						231	144	101	71	F 1/400
1,20	3920	1791	1011	650	450	322	239	194	151	F 1/200
						285	184	128	90	F 1/400
1,50	4235	2089	1535	1011	731	541	300	238	178	F 1/200
						511	265	185	125	F 1/400

Note: calculations made considering the minimum UNI tolerances on the thicknesses

Note: Arrow with limitation F 1/200 F 1/400

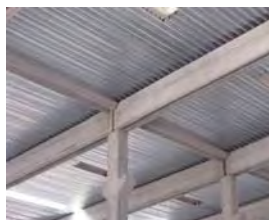

GENUS 55 S.C.

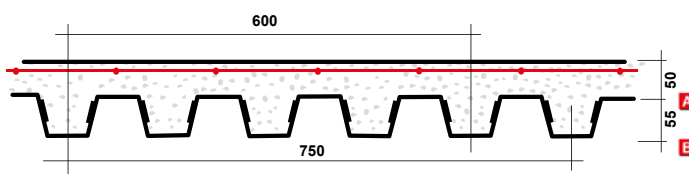

steel

Jet CLS 5 cm

ribbon development 1000: Useful width 600
ribbon development 1250: Useful width 750

thickness (mm)	weight (Kg/m ²)	Jxx (cm ⁴ /m)	Winf (cm ³ /m)	Wsup (cm ³ /m)
0,60	7,85	50,34	16,81	19,43
0,80	10,46	61,01	21,56	24,58
1,00	13,08	72,33	26,44	30,47
1,20	15,70	88,12	31,47	35,87
1,50	19,72	104,20	38,45	42,53

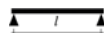

thickness (mm)	interaxis m								
	1,50	2,00	2,50	3,00	3,50	4,00	4,50	5,00	
T _{u,Rd} 0,105 N/mm ²	0,60	1870	1372	1021	701	437	295	186	-
	0,80	1980	1475	1143	803	595	460	270	141
	1,00	2015	1492	1178	912	663	515	291	163
	1,20	2046	1530	1192	945	732	545	309	174
	1,50	2067	1564	1192	945	780	597	335	193



Maximum permissible payload Kg/m²

thickness (mm)	interaxis m								
	1,50	2,00	2,50	3,00	3,50	4,00	4,50	5,00	
T _{u,Rd} 0,105 N/mm ²	0,60	1928	1440	1098	821	596	476	207	81
	0,80	2011	1512	1180	900	680	545	299	160
	1,00	2037	1531	1205	995	745	575	321	175
	1,20	2068	1582	1238	1025	800	608	340	192
	1,50	2099	1594	1238	1025	830	651	355	200

Note: calculations made considering the minimum UNI tolerances on the thicknesses

Note: Arrow with limitation F 1/200 F 1/400

Longitudinal sliding or vertical detachment are prevented as the corrugated sheet is anchored to the concrete casting. The following chart is intended to be taken as indicative reference. The presence of an electrowelded net applied before the casting is not taken into account. The designer, therefore, shall be responsible for the correct assessment of the specific case, both in terms of the casting stage (sheet stringing) and the operating one.



GENUS 60

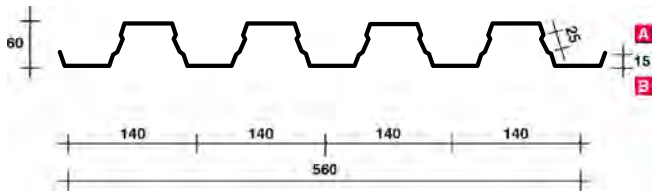

steel

thickness (mm)	weight (Kg/m ²)	Jxx (cm ⁴ /m)	Winf (cm ³ /m)	Wsup (cm ³ /m)
0,60	8,41	82,43	20,85	20,61
0,80	11,21	110,93	27,94	27,63
1,00	14,02	138,86	34,98	34,58
1,20	16,82	166,36	41,88	41,40
1,50	21,03	206,64	51,99	51,39

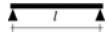

thickness (mm)	interaxis m									Arrow
	1,00	1,50	2,00	2,50	3,00	3,50	4,00	4,50	5,00	
0,60	1023	580	378	266	189	115	73	49	-	F 1/200
				89	52	-	-	-	-	F 1/400
0,80	1689	943	608	427	263	161	103	68	47	F 1/200
				124	73	45	-	-	-	F 1/400
1,00	2484	1371	879	613	342	209	135	90	61	F 1/200
				579	163	97	59	-	-	F 1/400
1,20	3379	1845	1176	817	424	260	168	112	77	F 1/200
				712	203	120	74	46	-	F 1/400
1,50	4824	2608	1649	1141	551	338	218	146	100	F 1/200
				915	263	157	97	61	-	F 1/400



Maximum permissible payload Kg/m²

thickness (mm)	interaxis m									Arrow
	1,00	1,50	2,00	2,50	3,00	3,50	4,00	4,50	5,00	
0,60	1472	851	474	301	200	153	120	97	73	F 1/200
		784	324	161	184	112	71	47	-	F 1/400
0,80	2648	1267	708	449	320	245	192	145	102	F 1/200
		1092	452	226	254	155	100	66	45	F 1/400
1,00	3480	1722	963	603	461	351	274	188	133	F 1/200
		1417	588	294	329	201	129	86	58	F 1/400
1,20	3958	2204	1233	748	615	466	338	232	163	F 1/200
		1753	731	364	404	247	159	106	72	F 1/400
1,50	5305	2939	1643	969	856	647	435	298	210	F 1/200
		2276	946	472	519	318	205	137	93	F 1/400

Note: calculations made considering the minimum UNI tolerances on the thicknesses

Note: Arrow with limitation F 1/200 F 1/400

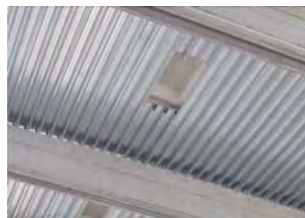

GENUS 60 Cassaforma a perdere

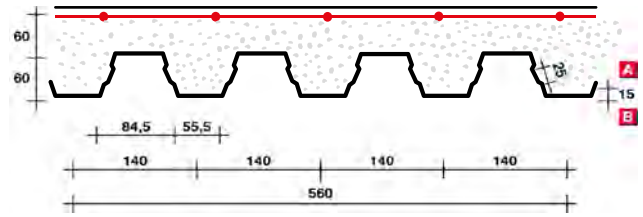

steel

Jet CLS 5 cm

thickness (mm)	weight (Kg/m ²)	Jxx (cm ⁴ /m)	Winf (cm ³ /m)	Wsup (cm ³ /m)
0,60	8,41	82,43	20,85	20,61
0,80	11,21	110,93	27,94	27,63
1,00	14,02	138,86	34,98	34,58
1,20	16,82	166,36	41,88	41,40
1,50	21,03	206,64	51,99	51,39

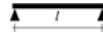

thickness (mm)	interaxis m							
	1,50	2,00	2,50	3,00	3,50	4,00	4,50	5,00
0,60	1842	1363	1012	697	436	278	181	-
0,80	1935	1456	1132	795	592	448	265	141
1,00	1998	1480	1155	907	659	511	282	163
1,20	2035	1515	1187	936	730	534	300	174
1,50	2040	1552	1187	936	773	588	327	193



Maximum permissible payload Kg/m²

thickness (mm)	interaxis m							
	1,50	2,00	2,50	3,00	3,50	4,00	4,50	5,00
0,60	1920	1401	1051	779	571	422	187	-
0,80	1966	1472	1147	812	609	462	281	157
1,00	2011	1500	1172	921	681	530	300	179
1,20	2054	1532	1200	957	762	548	318	192
1,50	2060	1570	1200	957	800	602	342	202

Note: calculations made considering the minimum UNI tolerances on the thicknesses

Note: Arrow with limitation F 1/200 F 1/400



GENUS 73

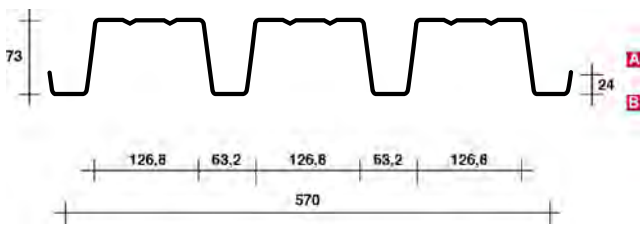

steel

thickness (mm)	weight (Kg/m ²)	Jxx (cm ⁴ /m)	Winf (cm ³ /m)	Wsup (cm ³ /m)
0,60	8,26	73,95	14,50	25,79
0,80	11,02	99,53	19,46	34,59
1,00	13,77	124,63	24,36	43,31
1,20	16,52	149,32	29,18	51,86
1,50	20,65	185,53	36,25	64,39

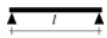

thickness (mm)	interaxis m										Arrow
	1,00	1,50	2,00	2,50	3,00	3,50	4,00	4,50	5,00		
0,60	1053	699	474	301	196	120	78	52	-	-	F 1/200
			337	168	94	55	-	-	-	-	F 1/400
0,80	1796	1194	671	427	264	162	105	70	48	-	F 1/200
		1094	455	227	127	76	46	-	-	-	F 1/400
1,00	2718	1551	869	552	332	203	132	88	59	-	F 1/200
		1370	569	285	158	94	58	-	-	-	F 1/400
1,20	3799	1924	1079	686	397	244	157	105	72	-	F 1/200
		1641	683	341	190	113	69	44	-	-	F 1/400
1,50	5704	2559	1436	868	493	303	196	131	90	-	F 1/200
		2040	848	423	236	141	87	54	-	-	F 1/400

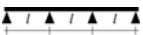

Maximum permissible payload Kg/m²

thickness (mm)	interaxis m										Arrow
	1,00	1,50	2,00	2,50	3,00	3,50	4,00	4,50	5,00		
0,60	777	431	280	193	140	106	83	65	53	-	F 1/200
							72	48	-	-	F 1/400
0,80	1249	707	468	328	240	182	142	113	93	-	F 1/200
						153	98	65	-	-	F 1/400
1,00	1791	1004	663	459	339	258	203	163	127	-	F 1/200
					312	192	123	83	56	-	F 1/400
1,20	2368	1314	903	627	460	351	276	215	152	-	F 1/200
					374	230	148	99	67	-	F 1/400
1,50	3253	1776	1149	820	634	460	348	267	189	-	F 1/200
				820	465	285	184	122	84	-	F 1/400

Note: calculations made considering the minimum UNI tolerances on the thicknesses

Note: Arrow with limitation F 1/200 F 1/400



GENUS 73 S.C.

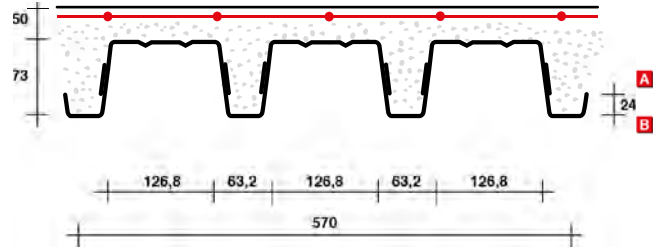

steel

Jet CLS 5 cm

thickness (mm)	weight (Kg/m ²)	Jxx (cm ⁴ /m)	Winf (cm ³ /m)	Wsup (cm ³ /m)
0,60	8,26	73,95	14,50	25,79
0,80	11,02	99,53	19,46	34,59
1,00	13,77	124,63	24,36	43,31
1,20	16,52	149,32	29,18	51,86
1,50	20,65	185,53	36,25	64,39

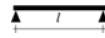

	thickness (mm)	interaxis m									
		1,00	1,50	2,00	2,50	3,00	3,50	4,00	4,50	5,00	
Tu,Rd 0,085 N/mm ²	0,60	1612	987	689	503	387	311	248	171	-	
	0,80	1697	1078	768	583	459	370	303	221	162	
										134	
	1,00	1677	1063	757	572	450	362	297	246	197	
										151	
1,20	1655	1048	744	563	442	355	290	240	199		
									167		
1,50	1621	1026	727	548	429	344	280	230	190		



Maximum permissible payload Kg/m²

	thickness (mm)	interaxis m									
		1,00	1,50	2,00	2,50	3,00	3,50	4,00	4,50	5,00	
Tu,Rd 0,085 N/mm ²	0,60	1635	1008	748	562	436	343	287	208	136	
	0,80	1715	1103	795	602	473	387	317	242	178	
	1,00	1689	1163	790	593	461	382	307	266	207	
	1,20	1671	1128	784	587	452	376	301	259	216	
	1,50	1633	1091	765	572	446	353	294	253	221	

Note: calculations made considering the minimum UNI tolerances on the thicknesses

Note: Arrow with limitation F 1/200 F 1/400

Longitudinal sliding or vertical detachment are prevented as the corrugated sheet is anchored to the concrete casting. The following chart is intended to be taken as indicative reference. The presence of an electrowelded net applied before the casting is not taken into account. The designer, therefore, shall be responsible for the correct assessment of the specific case, both in terms of the casting stage (sheet stringing) and the operating one.

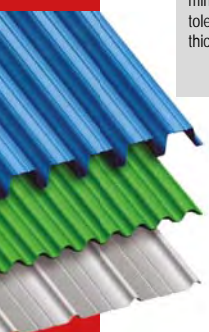

GENUS 160 positive

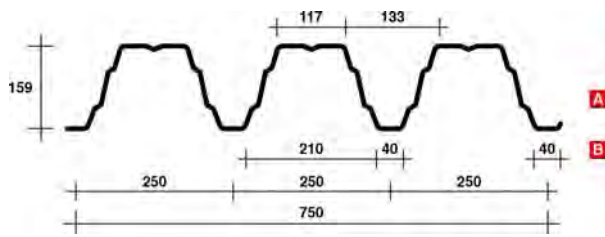

GENUS 160 negative

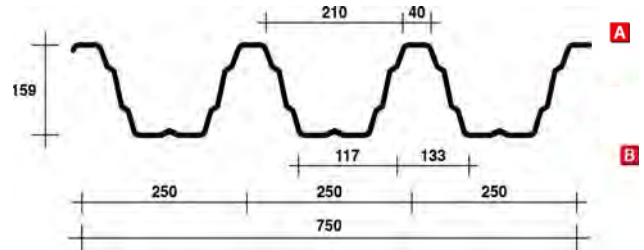

thickness (mm)	weight (Kg/m ²)	Jxx (cm ⁴ /m)	Wlow (cm ³ /m)	Wupp (cm ³ /m)
0,75	13,06	452,68	45,68	62,92
0,88	15,31	534,00	53,88	74,24
1,00	17,45	608,60	61,42	84,59
1,25	21,84	762,72	76,96	105,99
1,50	26,12	915,12	92,32	127,13

thickness (mm)	weight (Kg/m ²)	Jxx (cm ⁴ /m)	Wlow (cm ³ /m)	Wupp (cm ³ /m)
0,75	13,06	452,68	45,68	62,92
0,88	15,31	534,00	53,88	74,24
1,00	17,45	608,60	61,42	84,59
1,25	21,84	762,72	76,96	105,99
1,50	26,12	915,12	92,32	127,13

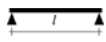

thickness (mm)	interaxis m									
	4,00	4,50	5,00	5,50	6,00	6,50	7,00	7,50	8,00	Arrow
0,75	386	307	247	185	140	107	83	64	51	F 1/200
	245	167	118	86	63	47	-	-	-	F 1/400
0,88	518	406	300	221	167	129	99	78	61	F 1/200
	293	201	142	103	76	56	-	-	-	F 1/400
1,00	619	484	348	257	194	149	115	91	71	F 1/200
	340	233	165	119	88	65	49	-	-	F 1/400
1,25	819	617	444	329	248	190	148	116	92	F 1/200
	434	298	211	153	112	84	62	-	-	F 1/400
1,50	1007	741	533	394	297	229	178	139	110	F 1/200
	520	357	253	184	136	101	76	56	-	F 1/400

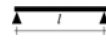

thickness (mm)	interaxis m									
	4,00	4,50	5,00	5,50	6,00	6,50	7,00	7,50	8,00	Arrow
0,75	321	271	214	161	123	88	62	49	-	F 1/200
	200	146	93	64	-	-	-	-	-	F 1/400
0,88	476	368	263	199	143	103	74	62	49	F 1/200
	251	178	118	80	51	-	-	-	-	F 1/400
1,00	588	432	320	221	168	119	96	78	55	F 1/200
	311	202	132	98	69	51	-	-	-	F 1/400
1,25	760	573	414	299	221	168	129	100	80	F 1/200
	399	261	194	138	88	65	-	-	-	F 1/400
1,50	921	706	499	361	265	201	157	116	91	F 1/200
	475	311	221	161	111	88	57	-	-	F 1/400



Maximum permissible payload Kg/m²

thickness (mm)	interaxis m									
	4,00	4,50	5,00	5,50	6,00	6,50	7,00	7,50	8,00	Arrow
0,75	234	194	162	138	118	103	90	79	69	F 1/200
						101	79	61	48	F 1/400
0,88	322	266	223	190	163	142	123	108	96	F 1/200
					158	121	94	73	57	F 1/400
1,00	407	339	286	244	209	182	158	140	123	F 1/200
				243	183	140	108	85	66	F 1/400
1,25	592	490	412	351	303	263	231	203	181	F 1/200
				309	233	179	139	108	86	F 1/400
1,50	776	640	536	455	391	339	297	261	232	F 1/200
			503	371	280	214	166	131	103	F 1/400



Maximum permissible payload Kg/m²

thickness (mm)	interaxis m									
	4,00	4,50	5,00	5,50	6,00	6,50	7,00	7,50	8,00	Arrow
0,75	211	165	127	110	90	79	63	61	49	F 1/200
						76	58	-	-	F 1/400
0,88	304	221	198	161	138	119	102	95	76	F 1/200
						109	78	51	-	F 1/400
1,00	389	301	252	210	167	163	132	121	99	F 1/200
						121	83	69	50	F 1/400
1,25	558	449	387	275	271	234	206	180	153	F 1/200
					200	150	106	90	67	F 1/400
1,50	752	600	465	341	342	302	250	230	186	F 1/200
					251	189	142	111	78	F 1/400

Note: calculations made considering the minimum UNI tolerances on the thicknesses

Note: Arrow with limitation F 1/200 F 1/400



Note: calculations made considering the minimum UNI tolerances on the thicknesses

Note: Arrow with limitation F 1/200 F 1/400



Sheets with concealed fixing

GENUS 330

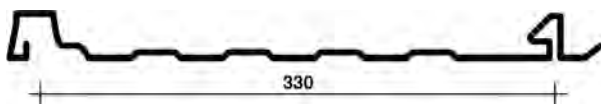

steel

thickness (mm)	weight (Kg/m ²)	Jxx (cm ⁴ /m)	Wxx (cm ³ /m)
0,60	7,33	3,55	2,33
0,80	9,77	4,85	3,13
1,00	12,22	6,14	3,94

thickness (mm)	interaxis cm.						
	60	80	100	120	150	200	250
0,60	810	455	259	150	77	-	-
0,80	1090	613	354	205	105	-	-
1,00	1372	772	448	259	133	56	-

thickness (mm)	interaxis cm.						
	60	80	100	120	150	200	250
0,60	1062	597	382	265	170	81	57
0,80	1429	804	514	357	229	111	78
1,00	1799	1012	648	450	288	140	98

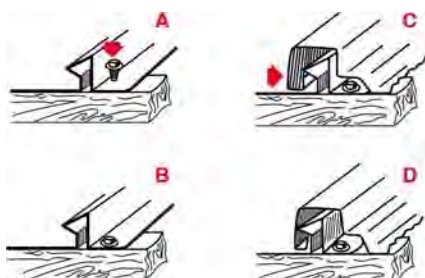

aluminium

thickness (mm)	weight (Kg/m ²)	Jxx (cm ⁴ /m)	Wxx (cm ³ /m)
0,70	2,94	4,14	2,68
0,80	3,36	4,79	3,09
1,00	4,20	6,14	3,94

thickness (mm)	interaxis cm.						
	60	80	100	120	150	200	250
0,70	229	129	83	57	-	-	-
0,80	265	149	95	66	-	-	-
1,00	337	190	121	84	-	-	-

thickness (mm)	interaxis cm.						
	60	80	100	120	150	200	250
0,7	301	169	108	75	-	-	-
0,8	347	195	125	87	56	-	-
1,0	442	249	159	111	71	-	-

GENUS 460

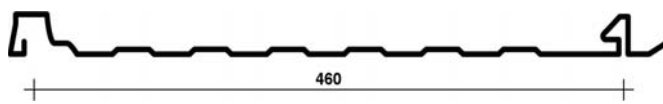

steel

thickness (mm)	weight (Kg/m ²)	Jxx (cm ⁴ /m)	Wxx (cm ³ /m)
0,60	6,59	2,55	1,67
0,80	8,79	3,48	2,25
1,00	10,99	4,41	2,83

thickness (mm)	interaxis cm.						
	60	80	100	120	150	200	250
0,60	581	327	186	108	55	-	-
0,80	782	440	254	147	75	-	-
1,00	984	554	322	186	95	-	-

thickness (mm)	interaxis cm.						
	60	80	100	120	150	200	250
0,60	762	428	274	190	122	58	-
0,80	1025	577	369	256	164	79	56
1,00	1291	726	465	323	207	100	71

aluminium

thickness (mm)	weight (Kg/m ²)	Jxx (cm ⁴ /m)	Wxx (cm ³ /m)
0,70	2,65	2,97	1,92
0,80	3,02	3,43	2,22
1,00	3,77	4,41	2,83

thickness (mm)	interaxis cm.						
	60	80	100	120	150	200	250
0,70	165	93	59	-	-	-	-
0,80	190	107	69	-	-	-	-
1,00	242	136	87	61	-	-	-

thickness (mm)	interaxis cm.						
	60	80	100	120	150	200	250
0,70	216	121	78	54	-	-	-
0,80	249	140	90	62	-	-	-
1,00	317	178	114	79	51	-	-

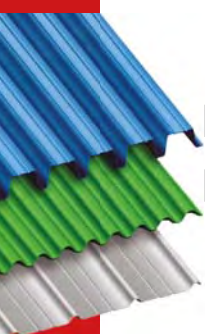

10 Perfect covering system

353

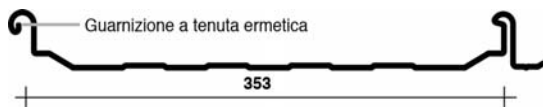

steel

thickness (mm)	weight (Kg/m ²)	Jxx (cm ⁴ /m)	Wxx (cm ³ /m)
0,60	6,67	7,05	2,85
0,80	8,90	9,56	3,86
1,00	11,12	12,04	4,86

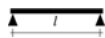

thickness (mm)	interaxis cm.								
60	80	100	120	150	200	225	275	300	
0,60	991	557	357	248	152	64	-	-	-
0,80	1344	756	484	336	207	87	61	-	-
1,00	1693	952	610	423	260	110	77	-	-

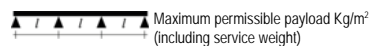

thickness (mm)	interaxis cm.								
60	80	100	120	150	200	225	275	300	
0,60	1299	731	468	325	208	117	92	62	-
0,80	1762	991	634	440	282	159	125	84	65
1,00	2220	1249	799	555	355	200	158	106	81

aluminium

thickness (mm)	weight (Kg/m ²)	Jxx (cm ⁴ /m)	Wxx (cm ³ /m)
0,70	2,68	8,18	3,30
0,80	8,90	9,43	3,81
1,00	11,12	12,04	4,86

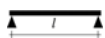

thickness (mm)	interaxis cm.								
60	80	100	120	150	200	225	275	300	
0,70	283	159	102	71	-	-	-	-	-
0,80	326	183	117	82	52	-	-	-	-
1,00	416	234	150	104	67	-	-	-	-

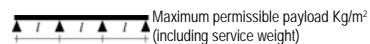

thickness (mm)	interaxis cm.								
60	80	100	120	150	200	225	275	300	
0,70	371	209	133	93	59	-	-	-	-
0,80	427	240	154	107	68	-	-	-	-
1,00	546	307	196	136	87	-	-	-	-

478

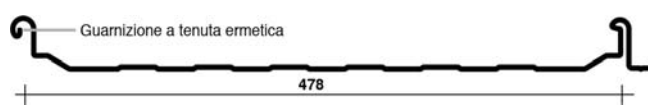

steel

thickness (mm)	weight (Kg/m ²)	Jxx (cm ⁴ /m)	Wxx (cm ³ /m)
0,60	6,16	5,20	2,10
0,80	8,21	7,06	2,85
1,00	10,27	8,89	3,59



thickness (mm)	interaxis cm.								
60	80	100	120	150	200	225	275	300	
0,60	732	412	263	183	113	-	-	-	-
0,80	992	558	357	248	153	64	-	-	-
1,00	1250	703	450	313	192	81	57	-	-

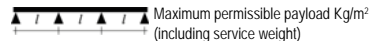

thickness (mm)	interaxis cm.								
60	80	100	120	150	200	225	275	300	
0,60	959	540	345	240	153	86	68	-	-
0,80	1301	732	468	325	208	117	93	62	-
1,00	1639	922	590	410	262	148	117	78	60

aluminium

thickness (mm)	weight (Kg/m ²)	Jxx (cm ⁴ /m)	Wxx (cm ³ /m)
0,70	2,47	6,04	2,44
0,80	2,83	6,97	2,81
1,00	3,54	8,89	3,59

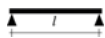

thickness (mm)	interaxis cm.								
60	80	100	120	150	200	225	275	300	
0,70	209	117	75	52	-	-	-	-	-
0,80	241	135	87	60	-	-	-	-	-
1,00	307	173	111	77	-	-	-	-	-

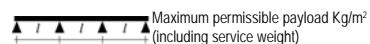

thickness (mm)	interaxis cm.								
60	80	100	120	150	200	225	275	300	
0,70	274	154	99	68	-	-	-	-	-
0,80	316	178	114	79	51	-	-	-	-
1,00	403	227	145	101	64	-	-	-	-



GENUS 10 Perfect

Genus 10 Perfect is a corrugated element for the covering of both civil and industrial buildings. Its profile allows avoiding external fixing points, thus eliminating infiltrations almost completely.

Assembly, besides being easy and quick (as shown by the sequence of drawings marked with letters A-B-C), doesn't require using any tool (clamps, seals, etc.). It perfectly adapts to any underlying structure. The profile consists of a double ribbing at the sealing point, which ensures exceptional solidity. It can be walked on when working at height.

The metal part can expand without damaging the fixing point as well as the anchoring one. This confers the system increased stability.

Since it's light, due to the limited width of the panels (353 and 478 mm), it's ideal for renovation works as it can be applied on pre-existing structures with no need to reinforce them.

The parts, having standard width of 353 and 478 mm, are curved and can reach up to 18 mm, if necessary. This avoids junctions with transversal overlaps, thus allowing performing coverings with gradients up to 5%. They can be sealing gasket ducts.

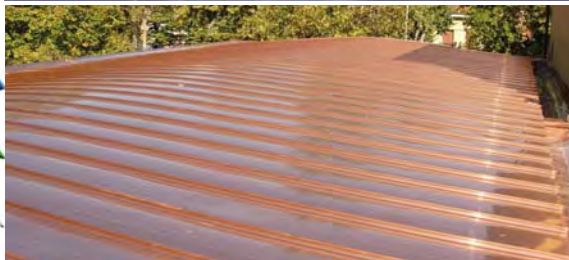
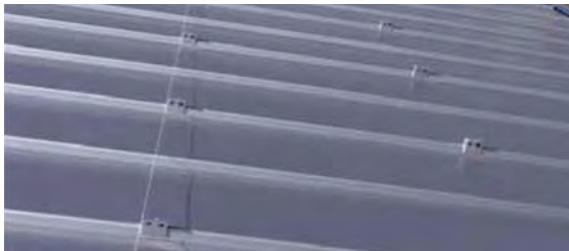
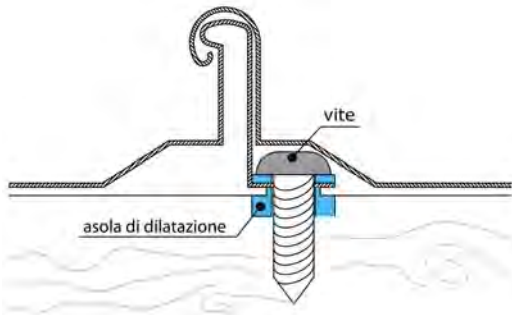
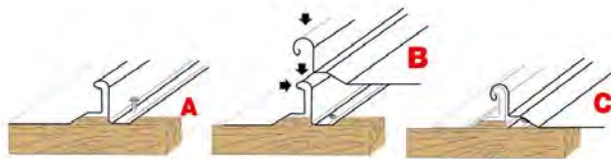

When working with covering elements belonging to the series 10 Perfect 478 and 10 Perfect 353, with sliding and direct fixing to the substructure, we suggest pre-drilling the sheet "edging" such holes while approaching the slope or the gutter. This operation helps the covering parts slide in order to compensate thermal expansion.

The following figure shows some examples of fixing distribution without slotted hole (hatched area) and with slotted hole (white area) according to the covering gradient.

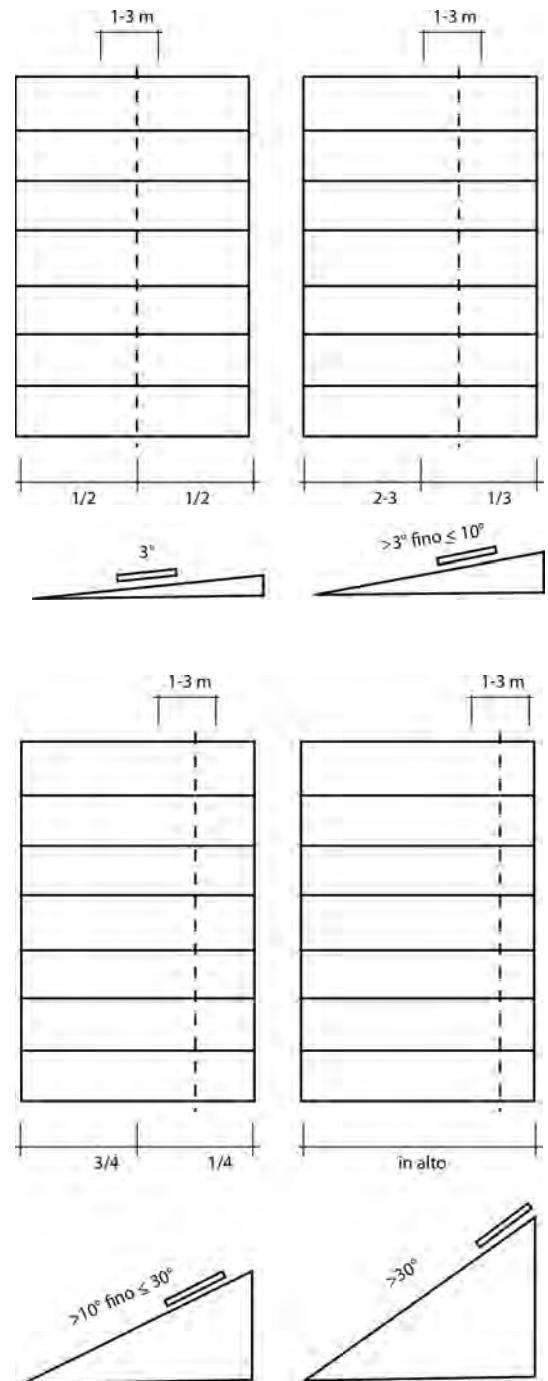

GENUS 10 Perfect

Snow catcher 1 hole

- fixing plate
- contrast plate with 1 hole $\varnothing 30$
- n. 2 screws with hexagonal head M8 st. steel

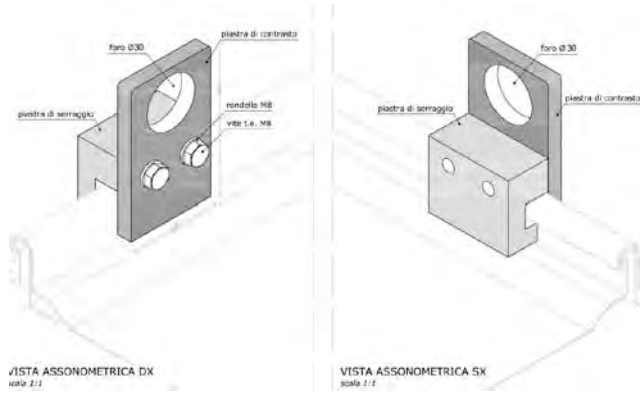

Snow catcher 2

- fixing plate
- contrast plate with 2 holes $\varnothing 30$
- n. 4 screws with hexagonal head

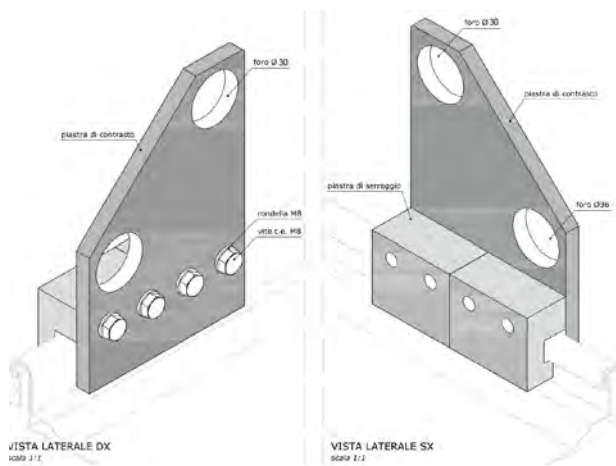

Bar-holder clamp

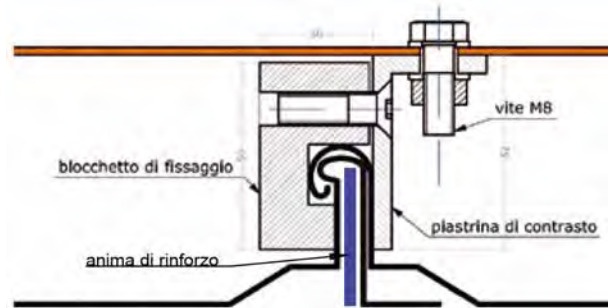

detail

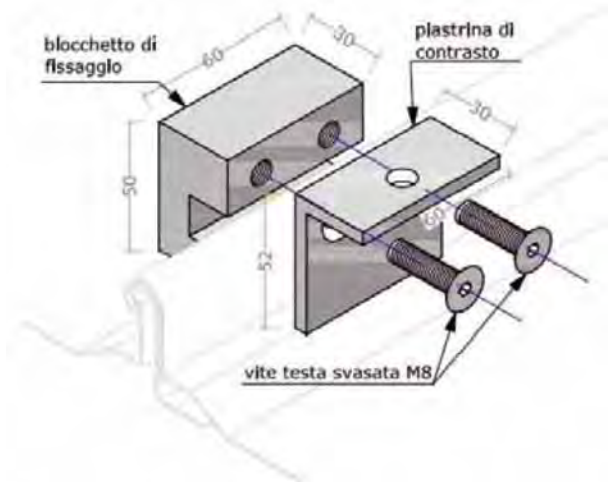

Standing seam coverings

Standing seam coverings and double standing seam ones

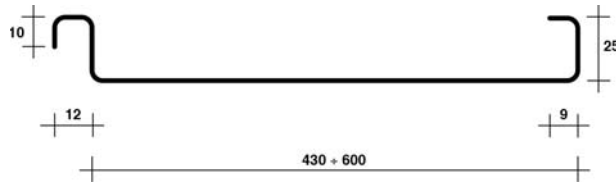

copper

thickness	interaxis 430		interaxis 600	
(mm)	weight (kg/m)	weight (kg/m ²)	weight (kg/m)	weight (kg/m ²)
0,60	2,70	6,30	3,60	6,00
0,80	3,60	8,35	4,48	8,00

Rheinzink

thickness	interaxis 430		interaxis 600	
(mm)	weight (kg/m)	weight (kg/m ²)	weight (kg/m)	weight (kg/m ²)
0,70	2,50	5,95	3,45	5,75
0,80	2,90	6,80	3,90	6,50

The term "vertical double seaming" or "double standing seam system" indicates a type of longitudinal junction of either the bands or the sheets placed outside the water flowing surface. Such junction is characterised by tightness to both rain and snow. No need of other methods.

Fixing is performed indirectly through flaps located inside the seaming. The flaps are provided with anchoring profiles along the ends of the sheets heads. The flaps can be: fixed, sliding and long sliding (see figure b-c). Our pre-profiled panels can be applied with radius $\geq 10-12$ m with no need of previous curving. Under such value, calendering performed with specific machineries is necessary.

A sub-structure with ventilated continuous support can facilitate the standing seam covering procedure (see picture).

Unimetal's qualified staff is available to explain any tool that might be necessary for the performance of the above-mentioned procedures, at any of its headquarters.

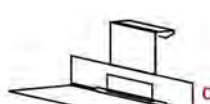
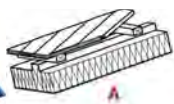

Double standing seam

Double standing seam is an evolution of the simple vertical standing seam system. It was mentioned for the first time in 1899. It is preferred to other systems for coverings up to 25° (minimum gradient 3° that is 5%). Its name indicates the type of longitudinal junction of the sheets, which protrudes from the water flow surface. The standing seam is only 25 mm high. It is characterised by tightness to the rain. This system is also suitable for easily covering concave or convex geometries, conical and spherical, by means of pre-curved or tapered sheets.

- Possibility to create particular geometries
- High compositional adaptability
- Integrated solar solutions
- Ecologically sustainable certified product

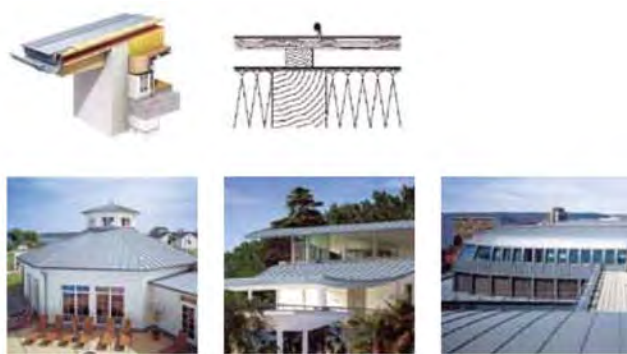

Angular standing

In the world of metal systems, angular standing seam is a relatively recent application. It is performed for coverings characterised by sheets with a gradient higher than 25°, which are therefore very evident. Closing the profiled sheets, in such case, is easier compared to double seaming systems as angular standing seam is finished with the first bending. This is why angular standing seam is mostly used for very visible coverings, with great attention paid to the compositional structure. It is also suitable for cornices, parapets and attics coverings. The sheets can be placed vertically, horizontally or obliquely.

- Aligned pattern of the sheets
- Integrated solar solutions
- Cheap and suitable for many geometrical shapes



Double standing seam

The "lath-like" joint is the oldest system among the application methods currently used. Its name indicates the type of longitudinal junction where, traditionally, a wooden lath complete with fixing flaps between the sheets is placed. With the Rheinzink-Klick system, such junction is optimised through small galvanised steel, which replaces the wooden lath. Both fixing systems are then covered with a butt profile. As both the sheets and the cap are produced in a single working stage through roll profiling machines, the Rheinzink-Klick system ensures the highest accuracy in terms of size as well as easy and quick application. The lath-like joints, thanks to their look, highlight the sheets modularity. This is why it is used for coverings with minor or high gradient. In order to obtain increased shading, the two systems can be combined: lath-like joint and standing seam.

- Simplified assembly through assembly of the elements
- Reduced use of machineries thanks to prefabrication
- Sheets length up to 20 m

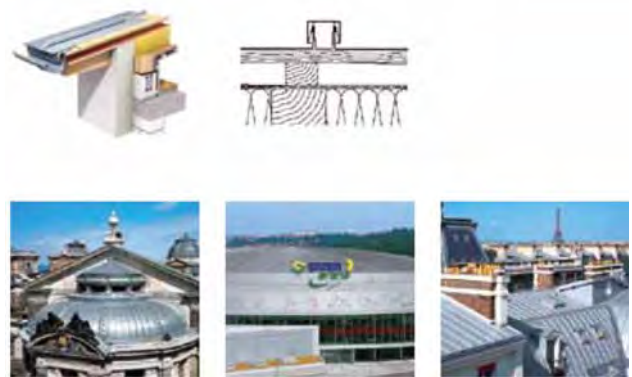

Standing seam coverings

GENUS Integra

vertical

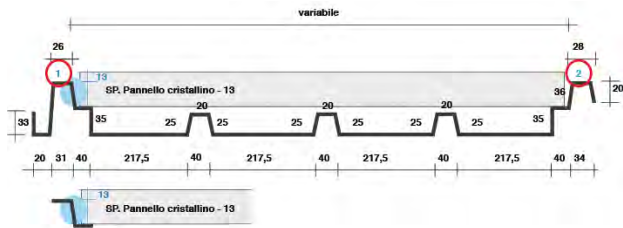

horizontal

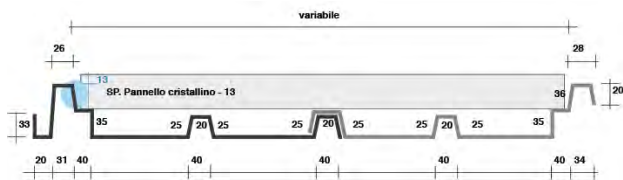

The waves 1,2, regarding height, must respect the thickness of the crystalline panel minus fixing thickness of 13 cm.
The wave 2 of the overlap must not exceed 28 mm.

External

The profile changes depending on the type of crystalline used. We suggest changing the three bases (217.5 mm) to reach the desired size.

"Energy Cop" kit

- 1 Seal
- 2 Lower anchoring attached to Unimetal sheet
- 3 Fixing upper plate
- 4 N.2 upper fastening screws

Standard fixing. The wave adapts to the fixing. We suggest n.10 fixings for a kwp of crystalline photovoltaic, n. 4 crystalline panels.

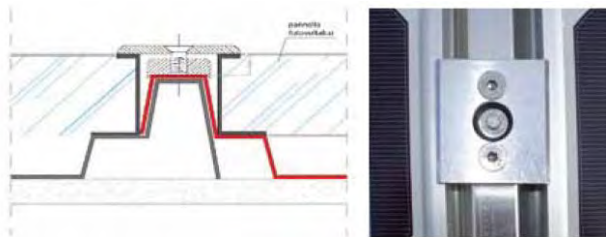

"Energy Cop" assembly stages

- 1 Application of covering with Genus Integra sheet with first Anchoring with seal (Energy Cop kit) that fits to the wave 1-2 with steel MiniBaz fixing (not provided) in the central hole.
- 2 Application of the crystalline panel. The sheet is fixed with the screws provided (n.2). These are fastened next to the hole using a hex key.

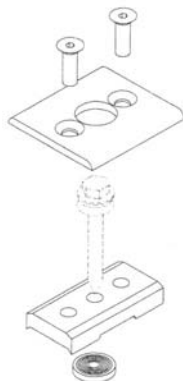

GENUS Integra Plus

Profile to integrate photovoltaic panels on a tiled roof.

vertical



horizontal



Accessories

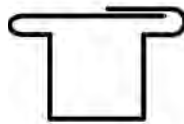

Intermediate fixing sheet

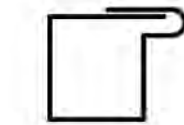

External fixing sheet

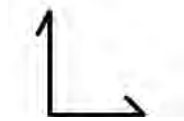

Finishing under-tile

Substructure

The fixing metal sheets shall be anchored to underlying structures whose pitch corresponds to the module length.

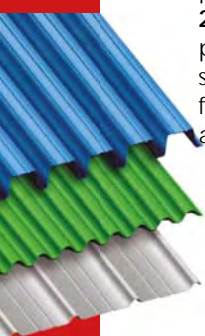

Colour chart

Standard ▲ for steel and aluminium

Other colours can be provided on unified shades (RAL colour chart) on request.

▲ The fidelity of the original colours depends on reproduction and printing technical possibilities.



white grey
RAL 9002

grey
RAL 7015 •

Sienna red
RAL 3011

dark brown
RAL 8019

green
RAL 6005 •

Gentian blue
RAL 5010 •

• standard only
for some
thickness and
surfaces

In the **charts** of this catalogue, the sheets are identified by means of letters and numbers corresponding to the main sizes of the section related to the sheet itself.

The order shall indicate the **code of the chosen sheet** followed by its thickness. For painted sheets, please indicate both the colour and the side (A or B).

The charts indicate the payloads P (kg/m²) according to the distance (cm) between two consecutive bases. The maximum loads indicated in the charts are the uniformly distributed loads besides service weight.

Corrugated sheets are provided in the length requested by the customer, as long as transport is possible. Length tolerance falls in a range of ± 5 mm.

It is the same as the source material. Therefore, **thickness tolerances** are the same used by steel companies, in compliance with UNI norms.

After application, water doesn't damage an aluminium **corrugated covering**. However, when the sheets are still stacked, humidity or water can stain them.

Although this doesn't imply the deterioration of the sheets, in terms of their aesthetics, we suggest **respecting the following indications**:

- For prolonged storage, store them in a warehouse.
- In case of temporary storage at the building site, accurately cover the sheets with at least one polyethylene sheet. In both cases, place the pallets on a sloping surface.

During **assembly**, especially in case of pre-painted and galvanised sheets, quickly remove all iron residues resulting from cutting procedures, holes, etc. They might stick to the surface and cause damages over time.



Technical specifications scheme

Corrugated profiles for coverings, walls and roofing

For a correct use of the technical specifications, replace the punctuation with the indications of your interest listed in the individual product data sheets.

The (covering/roofing) shall use Genus corrugated sheets

The sheets shall be profiled:

- hot-dip galvanised steel bands with "Sendzimir" (EN 10142 norm).
- Aluminium alloy 3105 H18 o H14 in compliance with Uni 485-2/-4.

Waves height mm

Waves Interaxis mm

Interaxis mm

Thickness mm

The sheets will be protected with a 5 micron thick primer layer on both sides and coated on the side (A or B) with a layer of 18 micron thick polyester resin paint.

The Genus sheets shall be fixed to the underlying structure by means of complete fixing assemblies consisting of:

- protection cap (coverings)
- sealing gasket
- screw diameter dim. mm X

The lateral overlap between the slabs is made with an overlap of n ° waves.

The sheet are assembled in a single piece from ridge to eave up to lengths of 12 meters, except for different requirements for particular conditions; for longer slab lengths, longitudinal overlaps can be made with overlap of not less than 150 mm depending on the slope of the stratum and the snow conditions.

Supply of a special anti-condensation absorbent product consisting of a gray non-woven fabric applied directly on the intradosal surface of the Genus sheet, when profiling by a support in an acrylic adhesive.

If an insulated cover is required, a thick insulation will be interposed between the extrados of the floor and the roof covering with density Kg/mc.



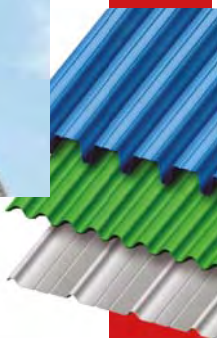

Materials

The corrugated profiles contained in this catalogue are available in the following materials:

- **Fe E 250 G steel** simply hot-dip galvanized with "sendzimir" process (or steel with Aluzinc coating. Galvanised and pre-painted with "coil coating" process (EN 10142 and EN 10169 norms). Application of a Primer with nominal thickness of 7 micron and of a paint layer with nominal thickness of 18 micron.
- **Pre-painted steel** guaranteed up to 30 years
- **Pre-painted aluminium** guaranteed colours
- **Aluminium alloy** 3105 H18 or H14 natural, H44 and H46 pre-painted (EN 485-2/-4 norm)
- **Stainless steel** Aisi 304 2B
- **Copper** 99,9 D HP (norma EN1172)
- **Outokumpu**
- **KIME**
- **Rheinzink**
- **Aluzinc**
- **Alucopper**



table of materials compatibility

MATERIAL	ALUMINUM	ALUZINK	GALVANIZED STEEL	STAINLESS STEEL	TITANIUM ZINC	COPPER
ALUMINUM	●	●	●	●	●	●
ALUZINK	●	●	●	●	●	●
GALVANIZED STEEL	●	●	●	●	●	●
STAINLESS STEEL	●	●	●	●	●	●
TITANIUM ZINC	●	●	●	●	●	●
COPPER	●	●	●	●	●	●

● Compatible materials ● Incompatible materials

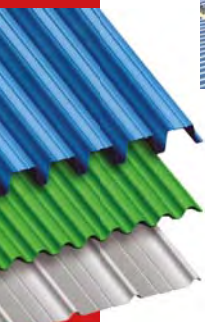
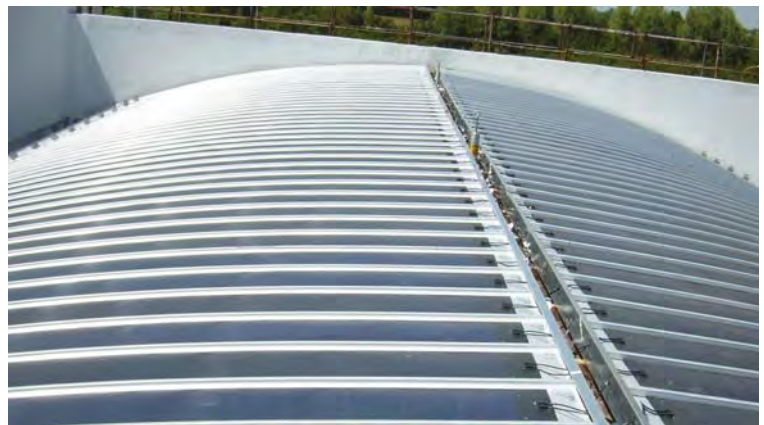
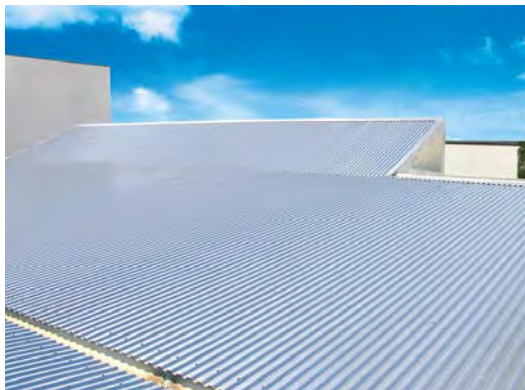

Alucopper

Special process that uses paints expressly conceived to make the material look like antique copper. This technical file is about the product applied on aluminium supports. The product is conceived for outdoor use (coverings, panels, metal systems, etc.). The base support used for Alucopper products is in aluminium:

- guaranteed 0t
- guaranteed for double standing seam

test	value	reference norm
covering	23-28	ECCA T1
brightness	20 ± 10	ECCA T2
pencil hardness	F - H	ECA T4
resistance	EXCELLENT	n.a.
resistance to metal marking	EXCELLENT	ECCA T2
TB cracking performed at 25°	0 T - 1 T	ECCA T7
TB cracking performed at 25°	0 T - 1 T	ECCA T6
adhesion on breakage deep drawing	100%	AICC N.1
adhesion on breakage impact draw	100%	ECCA T5

Available in several colours:

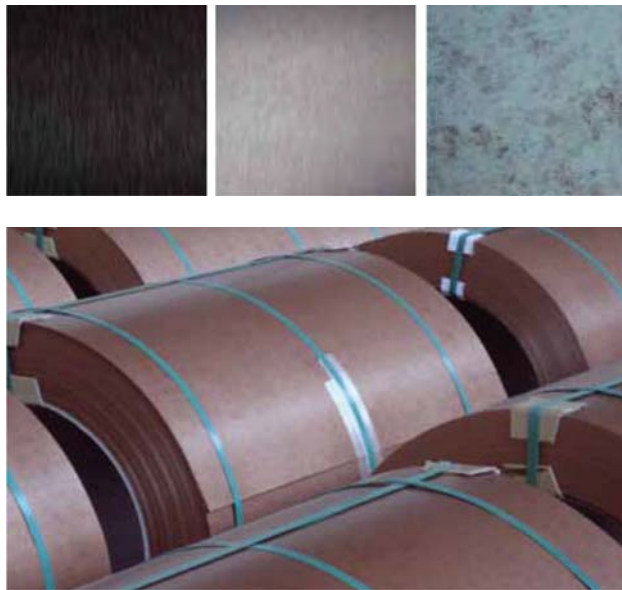

Rheinzink

Rheinzink is the commercial name of titanium zinc, produced according to DIN EN 98. It is a refined electrolytic zinc alloy, 99.995% pure, as envisaged by norm DIN EN 1179. It also contains small and well-defined parts of copper and titanium. The alloy composition is one of the factors that determine the technological properties of the material, as well as the colour of Rheinzink film. The raw material is fused, laminated and wrapped on a steel cylinder in a single, continuous operation. The material is uniform and flawless. They are then used as semi-finished products for further processes such as the production of metal systems, pre-fabricated items and profiles for coverings and high-quality façade coverings. Rheinzink titanium zinc comes in four product lines: film, protect, color, interior.

Properties of the material:

- Density (specific weight): 7.2 g/cm³
- Melting point: 418 ° C
- Recrystallisation limit: >300 ° C
- Longitudinal expansion coefficient (lamination direction): 2.2 mm / mx 100 K
- Expansion coefficient (transversal to the lamination direction): 1.7 mm / mx 100 K
- Elasticity module ² ≥ 80,000 N / mm²
- Non-magnetic
- Non-combustible

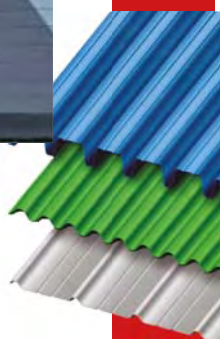

Rheinzink-patina line

All Rheinzink titanium zinc products meet the strict requirements of the norm EN 988 as well as the quality zinc criteria of TÜV Rheinland. Coating line sheets and coils are available in the bright-rolled version, blue-grey version and graphite-grey version.

Over time, Rheinzink-precoating acquires a natural iridescent grey or graphite-grey film, thanks to the action of weather agents. In the bright version, the formation of zinc carbonate becomes over time a visible, homogeneous grey film. The chromatic effect of the natural film is created at the plant through the pre-coating process. As this is not painting, but pickling, all the positive features of the surface are not altered. Rheinzink-preCoating sheets and coils, with bright-rolled and blue-grey finishings, can be provided with a protective film on request. Rheinzink preCoating semi-finished graphite-grey products, instead, are always provided with a protective film. This line of products also includes Rehizinc metal systems for rainwater discharge as well as the products for façade coverings and coating.

- Natural material
- The protective film is naturally formed
- Long-lasting. No maintenance needed
- 100% recyclable
- Resistant in different climate zones
- Flexible and resistant to frost
- Tested processability: profiling, bending, deformability
- Pre-coated surfaces available in the following finishings: blue-grey and graphite-grey
- Complete range of semi-finished products
- Wide array of metal systems
- Application for coverings, façades, metal systems and architectural details



Rheinzink-protect line

Protect line includes high-quality Rheinzink titanium zinc sheets and coils. These products meet the strict requirements envisaged by norm EN988 as well as the quality zinc requirements envisaged by TÜV Rheinland.

Rheinzink-protect products are available with blue-grey and graphite-grey finishings. They are provided with standard protective film. The product surface is characterised by a long-lasting, transparent paint that protects the "pre-coated" finishing. Processing at the production plant confers its typical natural look and titanium zinc veining. An interesting alternative available in both sheets and coils.

- Natural material
- Long-lasting protection of the surface through painting
- Protection of the typical pre-coated veining
- Long-lasting. No maintenance needed
- 100% recyclable
- Resistant in different climatic areas, flexible and resistant to frost
- Tested processability: profiling, bending, deformability
- Pre-coated surfaces available in the following finishings: blue-grey and graphite-grey
- Complete range of semi-finished products
- Application for coverings, façades and architectural details



Rheinzink-interieur line

The innovative interior line opens new possibilities for interior design. The sheets and the coils are in Rheinzink titanium zinc, in compliance with norm EN 988 and with the TÜV Rheinland quality zinc requirements. Rheinzink-interieur laminated materials are available with blue-grey and graphite-grey finishings and are provided with a protective film. In order to protect the finishings against wear in indoor environments, a long-lasting, transparent painting is applied on their surface. This helps keep the natural look over time as well as the typical veining of the "pre-coated" titanium zinc surface. This material is available in sheets and coils.

- Natural material
- Long-lasting protection of the surface through painting
- Protection of the typical pre-coated veining
- Long-lasting
- High aesthetic value
- 100% recyclable
- Tested processability: profiling, bending, deformability
- Pre-coated surfaces available in the following finishings: blue-grey and graphite-grey
- Complete range of semi-finished products
- Application for indoor environments and furniture design



Rheinzink-color line

The new colour line is the colour variant of our Rheinzink titanium zinc, ideal for both coverings and façade coating. Rheinzink-color is compliant with norm EN 988 as well as with TÜV Rheinland quality zinc criteria. Through the use of a one-of-a-kind system, the metal surface is coated with a PVDF-base coloured paint. The excellent processability characteristics of Rheinzink titanium zinc are not altered by this procedure. This line allows the designer to widen the range of compositional possibilities, having at his disposal a wide selection of RAL colours. At the same time, feel free to contact Rheinzink should you have questions regarding technical and design details as well as building techniques for façade coverings and coatings. All Rheinzink sheets and coils are provided with a protective film.

- Natural material
- Rheinzink quality now also with colour variant
- Wide range of colours on request
- High-quality, long-lasting PVDF paint
- UV rays resistant
- 100% recyclable
- Flexible and resistant to frost
- Tested processability: profiling, bending, deformability
- Complete range of semi-finished products
- Application for coverings, façades and architectural details



Quick Step-Treppendach

Trying to always come up with innovative solutions is the main requirement of modern architecture. This is why Rheinzink has developed a covering system based on pre-fabricated elements, which combines interesting compositional possibilities with easy application: QUICK STEP – Rheinzink Treppendach. This patented system is an innovative metal covering system with many application possibilities, which represents a prestigious alternative to traditional ones. QUICK STEP is ideal for roofs with different geometries with gradient between 10° and 75°. The pre-fabricated assembly components, all made with pre-coated Rheinzink with thickness of 0.8 mm, guarantee quick and easy assembly thanks to its special snap-in system. From a compositional point of view, QUICK STEP opens new horizons: its typical structure with steps makes for a horizontal pattern with an elegant and harmonious warping.

- Easy installation with the "assembly kit"
- Possibility of integration with photovoltaic panels
- Pre-coated natural finishings
- Horizontal pattern of the covering with "step" effect



Flakes

Rheinzink small scales are either square or lozenge-shaped. Unlike shingles or plates, which might seem similar, Rheinzink flakes have flaps on their 4 sides (two on the upper side and two on the lower one). They allow "enchainment" with simple standing seam systems. The flakes can be either handcrafted or produced industrially. Their small size allows coming up with building solutions even when working with complex geometries. This is why they are ideal for curved surfaces coverings, or for dormers, chimneys and cornices. Besides "small flakes", there are also Rheinzink "big flakes". The latter, with larger sizes and several formats, especially rectangular, allow covering surfaces having different patterns and are mainly used for extended façades. Besides, they are more and more used for inclined roofs as an alternative covering system, thus obtaining interesting optic effects.

- Flakes size on request
- High composition possibilities
- Finishings are subject to the formation of a natural film
- No maintenance required.



FACADE COVERINGS



Genus Wall slats
RheinZink façade coverings

Slats

GENUS Wall slat

Genus Wall is the slat with invisible fixing system that allows creating new original façade coverings that will renovate your buildings making them more elegant.

Installation is quick and easy thanks to the wide range of accessories:

- Extruded aluminium sub-structure that makes up for expansion and ventilation.
- Head elements closing and supply of angular pieces that ensure linear modularity, thus avoiding the use of edge benders.

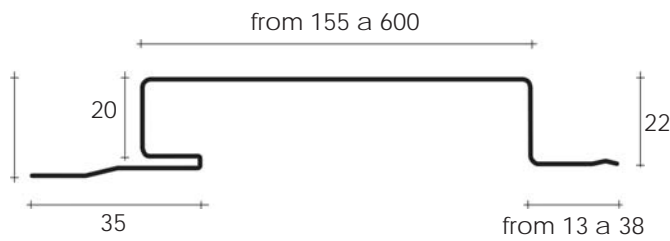

MATERIALS				
p.paint. steel	p.paint alum	copper	tit. zinc	st. steel
X	X	X	X	X
0,5-0,8 mm	0,8-12 mm	0,6-1,0 mm	0,8-1,0 mm	0,6-0,8 mm

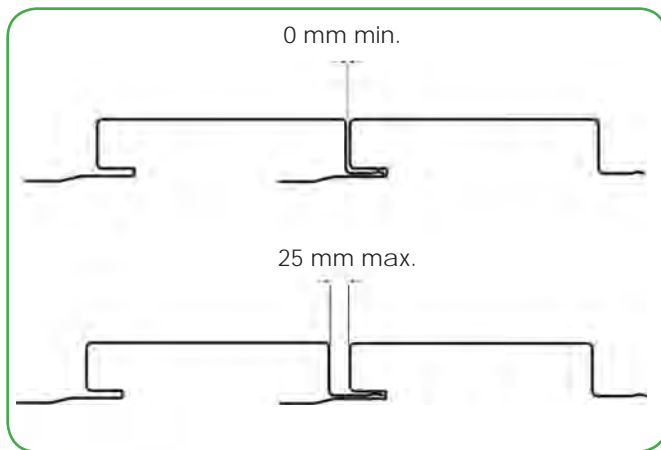
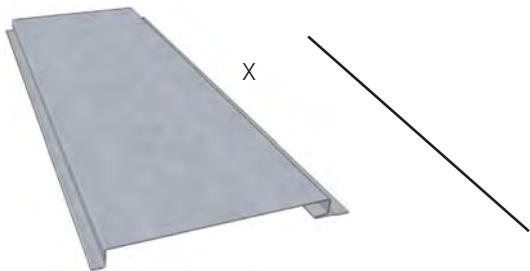

head elements closing



angular elements



ending angular pieces



window detail

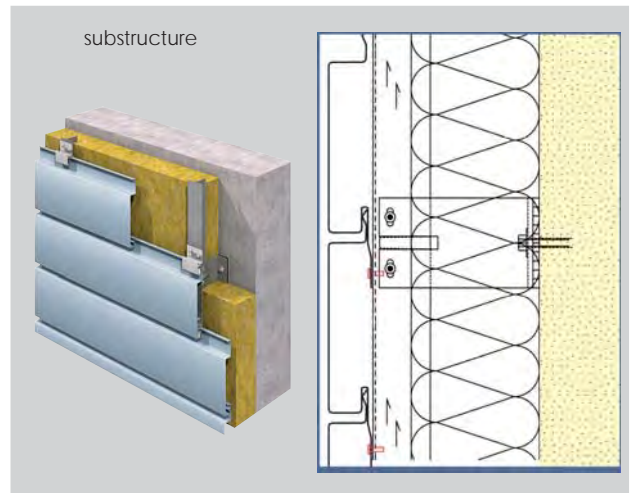

Support brackets for GENUS WALL slat

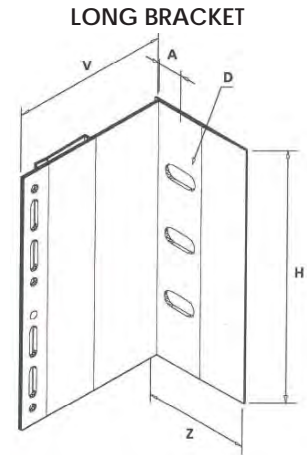
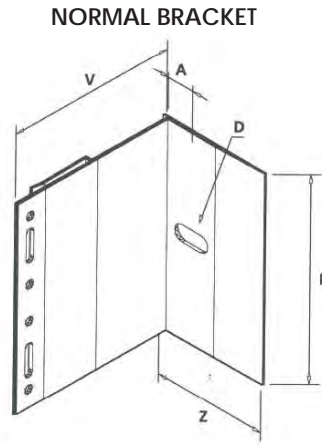
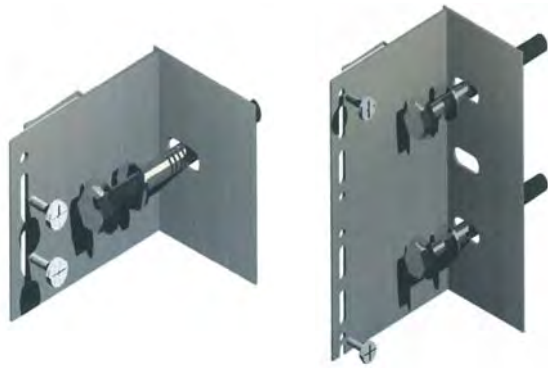

NORMAL BRACKET

DESCRIPTION	Bracket, movable or fixed, to fix the structure beams
MATERIAL	Extruded aluminium AL Mg Si 0,5 / F25
LENGTH (V) mm	40 - 60 - 90 - 120 - 150 - 180 - 210
HEIGHT H mm	120
D Ø mm	6,5x22 - 11 x 22 - 15x22
Z mm	60
A mm	20

LONG BRACKET

DESCRIPTION	Bracket, movable or fixed, to fix the structure beams
MATERIAL	Extruded aluminium AL Mg Si 0,5 / F25
LENGTH (V) mm	40 - 60 - 90 - 120 - 150 - 180 - 210
HEIGHT H mm	160
D Ø mm	6,5x22 - 11 x 22 - 15x22
Z mm	60
A mm	20

Beams for GENUS WALL slat

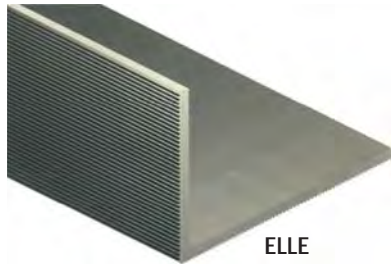

ELLE

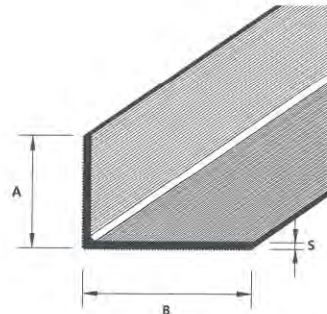

ELLE

DESCRIPTION	L profile of the beams					
MATERIAL	Extruded aluminium AL Mg Si 0,5 / F25					
LENGTH mm	6000					
A mm	25	40	60	40	40	40
B mm	25	40	60	60	60	80
S mm	2,0	1,8	2,5	1,8	2,2	1,8

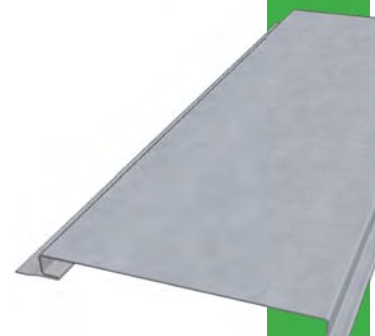

Façade coverings

Big flakes

This type is mainly used for wide façades in that it allows highlighting the typical profile of the big flakes.

By choosing the size, orientation and pattern of the flakes, it is possible to obtain different profiles, thus allowing the designer to create interesting patterns for the façade covering.

The "pre-coated" version (pickling process: light iridescent grey and dark grey) allows obtaining, right from its application, a homogeneous colour also avoiding glare during the initial period. Besides, in order to ensure adequate size for the different designs, the flakes can be manufactured individually for all patterns.

- Flakes size can be customised
- Several compositional possibilities
- Finishings are subject to the formation of a natural film
- Ecologically sustainable certified product



Small flakes

Rheinzink small flakes are either square or lozenge-shaped. Unlike shingles or plates, which might seem similar, Rheinzink flakes have flaps on their 4 sides (two facing forward on the upper side and two facing backward on the lower one). They allow "enchainment" with simple standing seams. Their small size makes for the identification of building solutions even when working with complex geometries. For this reason, they are suitable for the covering of dormers, chimneys and cornices.

- They are available in different sizes
- Geometric flexibility of the surfaces to be covered
- Finishings are subject to the formation of a natural film
- Long-lasting. No maintenance required

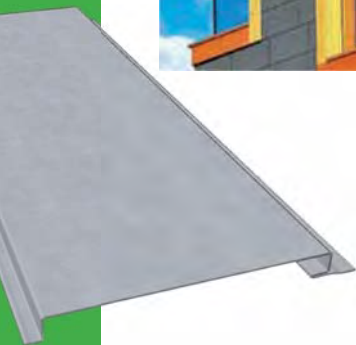
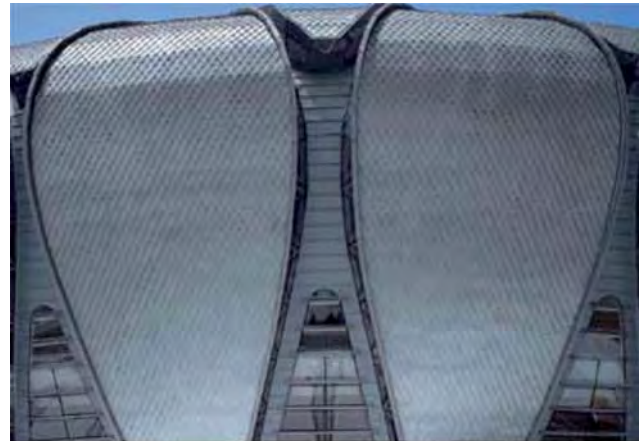
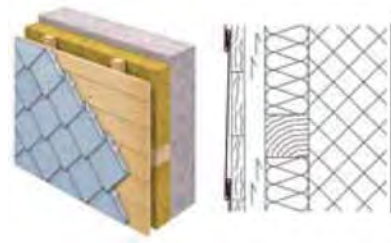

Angular standing seam

The standing seam systems offered by Rheinzink longitudinally connect the single sheets. Façade coverings usually require angular standing seam, which is characterised by a "modest mark" (width 12 mm), despite being visible as it is in relief.

For the sheets profiling and for the joints seaming, suitable portable devices are used. They allow reducing the number of the processing procedures as well as installation costs. The sheets maximum flexibility (variable interaxis and length) allows covering complex geometries too. Besides, you can choose the longitudinal joints direction (vertical, horizontal, oblique) as well as the positioning of transverse joint.

- It adapts to several geometrical shapes
- Available with different interaxes
- Finishings are subject to the formation of a natural film
- Long-lasting. No maintenance required



Horizontal slats

The so-called "horizontal slats" look like "insertion slats". Due to their origins, they remind of wooden façade coverings.

The panels provided with beading along the two sides, are fixed on the sub-structure by means of an extruded aluminium profile. Commissure is equal to 20 mm. Thermal expansion is safely absorbed thanks to this specific anchoring

- Horizontal partition of the façades
- Available with different interaxes
- Running fixing, free expansion
- Slats length up to 6 m

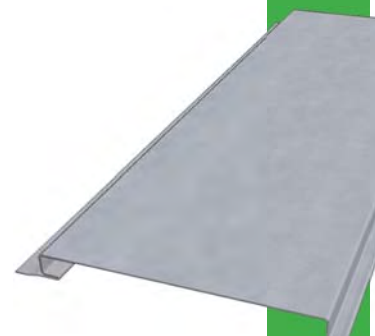
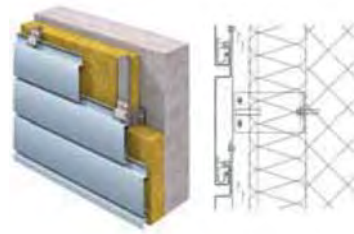

Cantilevered slats

The “flaked” look without commisure of the ‘cantilevered slats’ represents an original covering solution. The light reflecting on the profile particular geometry creates interesting light-shadow patterns. According to a detailed design stage, the slats are prefabricated in a way that makes their installation easy and cheap

- It is similar to wooden coverings with cantilevered panels
- Available with different interaxes
- No maintenance required, no lacquering
- Pre-coated finishings + color line

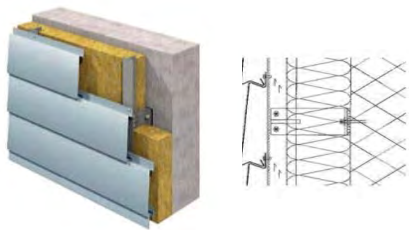

Insertion slats

The main advantage provided by the insertion slats lies in the possibility to choose both the interaxis, between 200-333 mm, and the commissure width, between 0-30 mm. This possibility, together with the possibility to choose the orientation of the slats during their application (vertical, horizontal, oblique), offers wide design opportunities. Items with different shapes can be successfully covered: during renovation works, long-lasting and high-quality solutions can be quickly created.

- Slat system with different patterns available
- Available with lines and interaxes having different widths
- Pre-coated finishings + color line
- Ecologically sustainable certified product

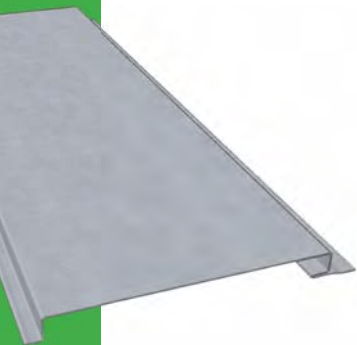
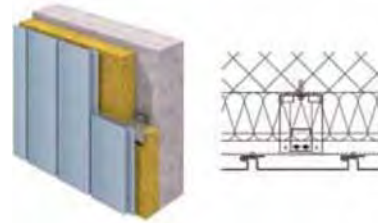

Undulating profiles

The sine wave fluid shape confers the undulating profiles a harmonious pattern.

The possibility to apply the sheet horizontally, vertically or obliquely makes for both a "refined" structure of the covering surfaces and a "pronounced" division of the areas it consists of.

The light and shadow effects create a pleasant and lively visual pattern, which is more evident in wide façades. The waves that characterise the sheets available have different sizes.

- Flexible application in larger formats
- Pronounced look of the façade
- Pre-coated finishings + color line
- Different sine wave profiles available on request

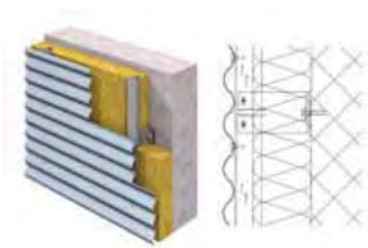

Corrugated profiles

The characteristic shaped profile of the corrugated ribs confer a formal look in all applications: horizontal, oblique and vertical. The contrast, more evident depending on the light, is more intense compared to corrugated profiles.

The possibility to choose between side A and B for each profile makes it a "two-sided" covering.

- Flexibility with larger sizes
- Pronounced pattern of the lines on the façade.
- Pre-coated finishings + color line

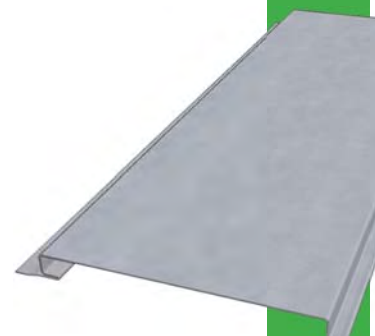
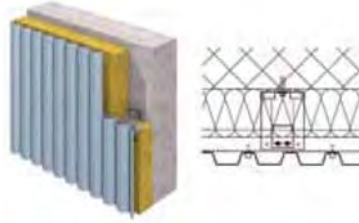

Façade coverings

Examples of application

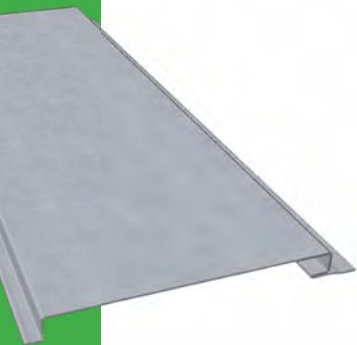

ACCESSORIES FOR COVERINGS INSULATING, ROOF VENTILATION



Solid polycarbonate
Alveolar polycarbonate
Fibre glass sheets
Genus Accessories
thermal and sound insulators
Rockwool
Isover thermal and
sound insulators
Klober thermal and
sound insulators
Roof ridge
Roof drains
Safety drain for roofs

Solid polycarbonate

standard measure
or other values
▲ on request

Greca 76/18 - GENUS 2000

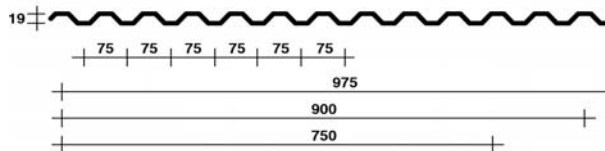

GENUS 950

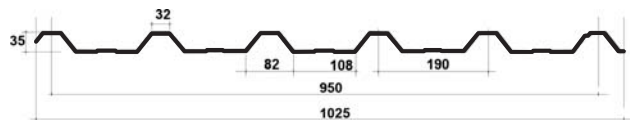

GENUS 1000/ UNI 1000

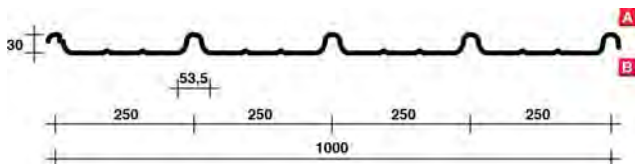

GENUS 900

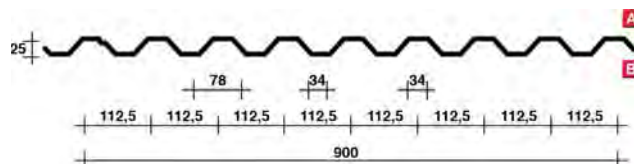

UNI 5

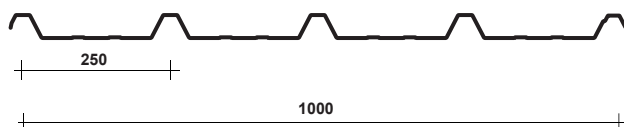

UNI 28

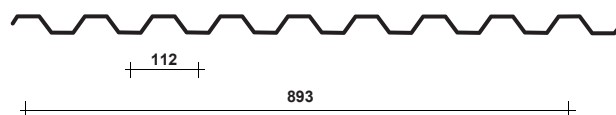

Alveolar polycarbonate

Thickness 2,5 mm



UNI 5

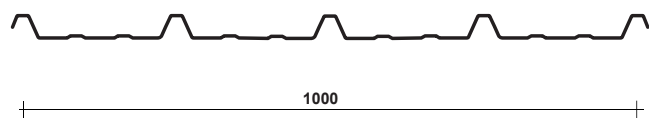

Thickness 8/10/16 mm

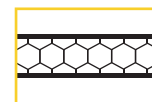

UNI 5

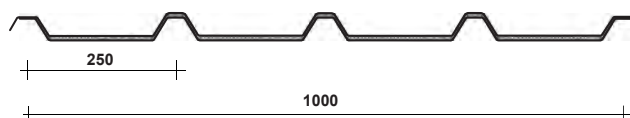

ONDA 76/18

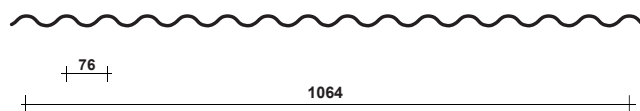

GRECA 76/18 - GENUS 2000

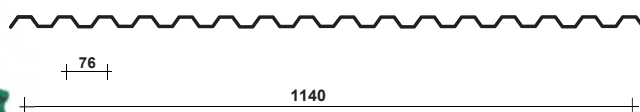

Alveolar polycarbonate

Modulit 10 Eco

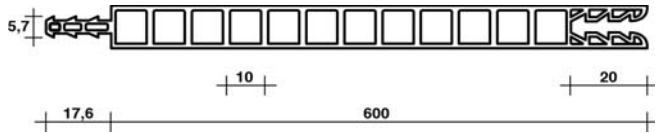

thickness (mm)	width	length	weight (Kg/m ²)	c. thermal insulation
10	600	6000	1,5	3,2 W/m ² °C

Modulit system is used for all those solutions that require: lightness, thermal insulation, resistance to impacts, high light transmission, self-extinguishing capacity.

Macrolux Super life two walls structure

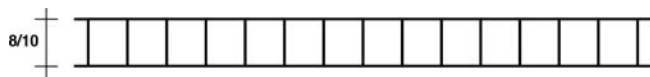

thickness (mm)	width	length	weight (Kg/m ²)
8	2100	6000s	1500
10	2100	6000s	1700/2000

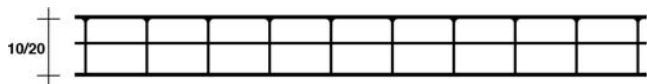

thickness (mm)	width	length	weight (Kg/m ²)
10	2100	6000s	2000
16	1050/2100	7000/6000s	2700/3000
20	2100	6000s	3100

two additional types of Macrolux sheets are available:

- **Macrolux heat shield:** thanks to its special manufacturing process, it has a reflecting surface that rejects solar rays, thus preventing greenhouse effect.
- **Macrolux Long life:** thanks to the special structure of its diagonal wall section, it confers great resistance to static loads.

Macrolux Super life accessories

Macrolux sheets are provided with a series of accessories.



H-shaped polycarbonate junction profiles.



Anodised aluminium junction profiles complete with thermal breaks, screw holders, screws and seals.



Aluminium adhesive tape for headers closure.

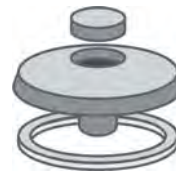

Fixing washers.

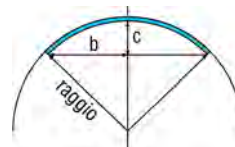

geometrical relations
 $r = \frac{b^2 + c^2}{2c}$

Macrolux sheets can also be used for curved structures. Minimum curvature radius:
 $r \text{ min.} = 150 \times \text{sheet thk.}$



Fibreglass sheets

Translucent coverings



light supports (cm)	capacity daN/m ²
50	600
60	201
70	147
80	113
90	89
100	72
110	58

Both the sheets and the coils can be produced in compliance with Class 1 (one) of fire-reaction according to national norms CSE RF 2/75 and CSE RF 3/77 (M.D. of 26/04/84). They can also be produced with self-extinguishing capacity as envisaged by international norms ASTM D 635 - 56 T. We'd like to stress that required minimum weights amount to Kg. 1.80/m² as regards sheets and Kg. 1.40 for coils.

Technical features:

- Specific weight: 1.40gr/cm³, sheet average thickness: 2 mm
- Light transmission: 80% neutral colour
- Operating temperature: -40°C +125°C
- Heat transmission K coefficient: 4.80 Kcal/sqm h°C
- thermal conductivity I coefficient: 0.20 Kcal/m² h°C
- Hardness: 55 ÷60 Barcol
- Linear thermal expansion: 3.05x10⁻⁵ cm/cm °C
- Elastic bending modulus: 60x10³ Kg/cm² Fire reaction: Class 1 (norm CSE RF 2/75/A and CSE RF 3/77)

Genus accessories

Curved sheets

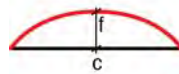

$$r = \frac{\left(\frac{c}{2}\right)^2 + f^2}{2f}$$

formula to work out the curvature radius

For falseworks, Genus profiles can be bent through micro-marking. Radiuses on request starting from 600 mm except for profiles Comet, Genus 60, 73 and 160.

Ridge sheet



Curved printed ridges having the same profile as the covering.

Genus profiles are provided with a series of standard accessories, or on request, which make it a real integrated covering system that meets every design need.

Curved connections

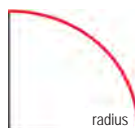
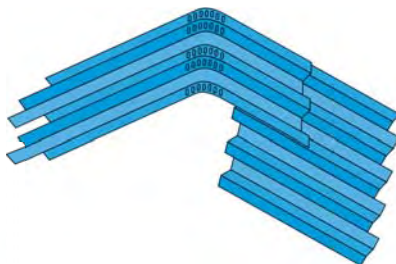

Functional and architectural elements obtained by marking. They can connect one wall to the covering.

Partially curved sheet

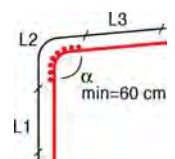

Obtained by cold forming bands that are later bent in order to obtain bent curves, according to design drawings, with the requested radius.

Curved flashing

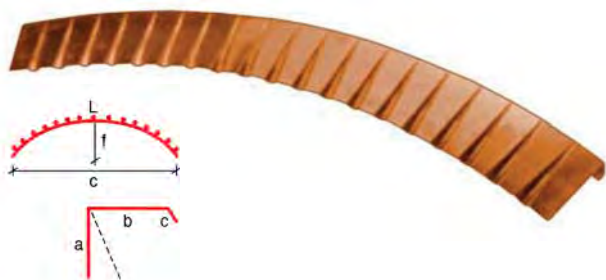

Made with faceplate elements that are press-bent and then curved through equidistant trapezoidal printed marks.

Press-bent ridge



Produced with sheets, with the requested material, using presses with angles and size requested by the design.

Notched flashing

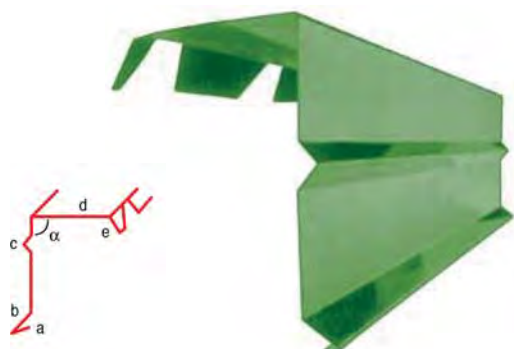

It is used to connect press-bent elements in the roof-covering head wall area. Produced with the pattern provided by the customer.

Notched ridge

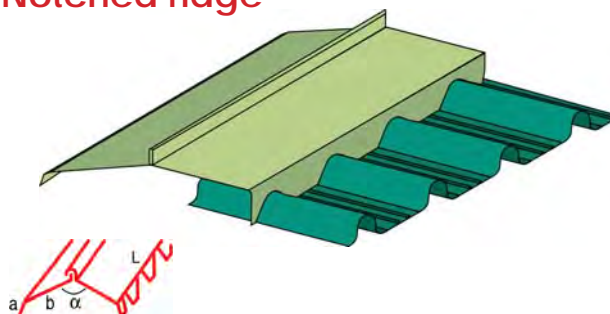

It allows connecting the press-bent components, according to the design, to the corrugated covering profiles. Overlaps are fixed through sealants and rivets.

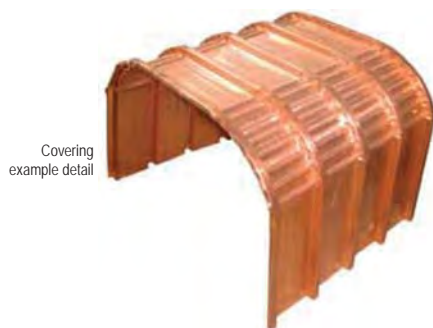

Genus soft anti-condensation

On the inner side of **Genus 800** profiles (cod. 75103 anti-condensation felt), **Genus 900**, **Genus 950**, **Genus 2000** (cod. 75101 antiq. felt) **Genus 1000** (cod. 75100 antic. felt) and **Genus 10 Perfect** it is possible to apply a Genus soft felt resistant to condensation built-ups resulting from the metal covering in the coldest moments of the day. Thanks to its excellent physical properties, the felt can also be used as:

- sound barrier for noises caused by weather events.
- dielectric strip to avoid electrolytic couple effect.

Genus soft is based on a fibre structure deriving from micro-spheres technology. Its fibre-microspheres structure can absorb over 900 grams of water condensation per square metre (according to the roof inclination).

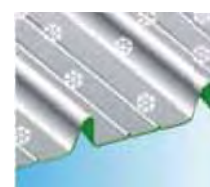
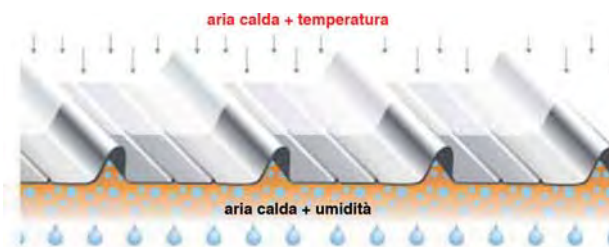

Polyethylene sound-proof covering



Used in order to reduce noises caused by weather agents, besides preventing the formation of condensation. Thickness of about 3 mm.

Isover Rollo Insulator CE



type	thickness	size
ROLLO	50	1,00X14,00
	50	1,20X14,00
ROLLO K	50	1,20X14,00

type	thickness	size
ROLLO	60	1,00X12,50
	60	1,20X12,50
ROLLO K	60	1,20X12,50
	60	1,20X12,50

Thermal resistance

type	thickness	size
ROLLO K	100	1,20X7,50

Thermal conductivity at 10°C $\lambda = 0,045$ W/mk

thickness mm	50	60	80	100
ROLLO K	1,10	1,35	1,75	2,20

Glass wool felt, not treated with thermosetting resins. One side is covered with kraft paper glued with bitumen (ISOVER ROLLO K felt). Also available without covering (ISOVER ROLLO felt).

- Isover Rollo CE felts are packed in rolls with heat-treated polyethylene. They are available in bulk or they can be palletised in overcompressed form.
- Overcompression allows transporting more rolls considering the loading volume of the vehicle. It also makes for reduced encumbrance. It is cost effective. Guaranteed thermal performance.
- Use: thermal and sound insulation. Industrial coverings.

Wooden laths L=4 m section 5x4 cm



Bituver Tender

type	framework	thickness mm	m ² for pallet
K3V	GLASS FIBRE	3,0	250
K4V	GLASS FIBRE	4,0	250
K4VP ▲	GLASS FIBRE + POLYESTER	4,0	250
K3PH	POLYESTER	3,0	250
K4PH	POLYESTER	4,0	250

Elastoplastometric water-proof membranes, with either fibre glass or polyester framework, continuous thread. Also available with double fibre glass or polyester support. Uses: waterproofing of flat/inclined coverings with all kinds of load-bearing structures, underground structures, etc.



Breathable underlying sheath

Sepa sec® and **Perno sec**® (code 58314): breathable underlying sheaths to be applied between planking and the metal covering. Ideal both for ventilated and non-ventilated coverings. Leader product on the German market. The sheath can be easily transported, cut and applied. With a little practice, it is possible to apply up to 50 m² per hour.

Thanks to the special bi-adhesive tape Air Grip® (code 58319), the junction (overlapped) is wind and weather conditions resistant. This product is based on modified butyl rubber. It doesn't contain solvents, halogens or silicon. It is bitumen and chlorine free. Application is possible with temperatures from +5°C.



Acrylic adhesives

Acrylic adhesives for Eternit treatment, compliant with the provisions of M.D. 20/08/99, CERTIFIED BY ISTITUTO GIORDANO SpA.

Cemblock base: latex based on acrylic resins for the removal of materials containing asbestos. It is an encapsulating paint, of the penetrating type.

Cemblok fil tipo A (57635) **tipo B** (57636): encapsulating covering for products exposed to weather phenomena (type A) as well as for the ones exposed in living spaces (type B).

Cemblock film tipo C (57637): encapsulating covering, ideal for over-covering old roofs containing asbestos.



Thermal and sound insulators

Durock Energy

Non-coated, rock wool, rigid panel, with double density. Highly resistant to compression, walkable, for thermal and sound insulation and safety in case of fire. Size 1200x600 mm.

Density of the upper layer 210 kg/m³. Density of the lower layer 130 kg/m³.

$\lambda_D = 0.037$ W/mK

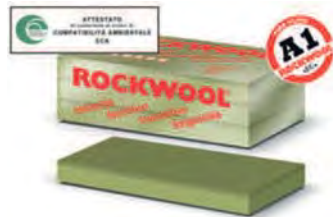

CODICE ARTICOLO	DESCRIZIONE ARTICOLO	MISURE mm
		b x l
A0023908	DUROCK E. 155 KG/MC N/RIVESTITO sp. 60 mm	1200x600
A0023910	DUROCK E. 155 KG/MC N/RIVESTITO sp. 80 mm	1200x600
A0023912	DUROCK E. 155 KG/MC N/RIVESTITO sp. 100 mm	1200x600
A0023913	DUROCK E. 155 KG/MC N/RIVESTITO sp. 120 mm	1200x600
A0023914	DUROCK E. 155 KG/MC N/RIVESTITO sp. 140 mm	1200x600
A0023915	DUROCK E. 155 KG/MC N/RIVESTITO sp. 160 mm	1200x600
A0023916	DUROCK E. 155 KG/MC N/RIVESTITO sp. 180 mm	1200x600

Hardrock Energy

Non-coated, rock wool, rigid panel, with double density. Highly resistant to compression, walkable, for thermal and sound insulation and safety in case of fire. Size 1200x600 mm and 2400x600 mm.

Density of the upper layer 190 kg/m³. Density of the lower layer 90 kg/m³.

$\lambda_D = 0.036$ W/mK



CODICE ARTICOLO	DESCRIZIONE ARTICOLO	MISURE mm
		b x l
A0052807	HARDROCK ENERGY N/RIVESTITO sp. 60 mm	1200x600
A0052826	HARDROCK ENERGY N/RIVESTITO sp. 80 mm	1200x600
A0052808	HARDROCK ENERGY N/RIVESTITO sp. 100 mm	1200x600
A0052825	HARDROCK ENERGY N/RIVESTITO sp. 140 mm	1200x600
A0052836	HARDROCK ENERGY N/RIVESTITO sp. 60 mm	2400x600
A0052835	HARDROCK ENERGY N/RIVESTITO sp. 100 mm	2400x600
A0052830	HARDROCK ENERGY N/RIVESTITO sp. 120 mm	2400x600
A0052834	HARDROCK ENERGY N/RIVESTITO sp. 140 mm	2400x600
A0052845	HARDROCK ENERGY N/RIVESTITO sp. 160 mm	2400x600

Hardrock Max

Non-coated, rock wool, rigid panel, with double density. Highly resistant to compression, walkable, for thermal and sound insulation and safety in case of fire. Size 1000x600 mm.

Density of the upper layer 220 kg/m³. Density of the lower layer 150 kg/m³.

$\lambda_D = 0.040$ W/mK



CODICE ARTICOLO	DESCRIZIONE ARTICOLO	MISURE mm
		b x l
A0052819	HARDROCK MAX N/RIVESTITO sp. 60 mm	1000x600
A0052820	HARDROCK MAX N/RIVESTITO sp. 80 mm	1000x600

Rockacier B Soudable

High-density, rock wool, rigid panel (double density for thickness ≥ 100 mm). Highly resistant to compression, walkable. One side is covered by a layer of bitumen (protected with a propylene film) for thermal and sound insulation.

Size 1200x1000 mm.

Density for thk. from 50 to 80 mm 135 kg/m³

Density for thk. ≥ 100 mm roughly 155 kg/m³ (upper layer 220 kg/m³; lower layer 140 kg/m³) $\lambda_D = 0.039$ W/mK

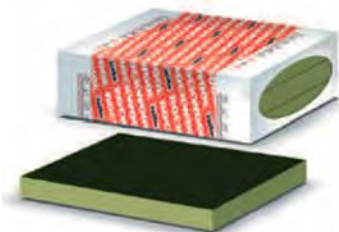

CODICE ARTICOLO	DESCRIZIONE ARTICOLO	MISURE mm
		b x l
A0052837	ROCKACIER B SOUDABLE BITUMATO sp. 50 mm	1200x1000
A0052849	ROCKACIER B SOUDABLE BITUMATO sp. 60 mm	1200x1000
A0052850	ROCKACIER B SOUDABLE BITUMATO sp. 80 mm	1200x1000
A0052844	ROCKACIER B SOUDABLE BITUMATO sp. 160 mm	1200x1000

Airrock DD

Rock wool, rigid panel. Non-coated with double density. For thermal and sound insulation. Size 1200x600 mm.

Density of the upper layer 105 kg/m³. Density of the lower layer 45 kg/m³.

$\lambda D = 0.035 \text{ W/mK}$



CODICE ARTICOLO	DESCRIZIONE ARTICOLO	MISURE (mm)
		b x l x sp
A0052813	AIRROCK DD N/RIVESTITO sp. 60 mm	1200x600x60
A0052812	AIRROCK DD N/RIVESTITO sp. 80 mm	1200x600x80
A0052811	AIRROCK DD N/RIVESTITO sp. 100 mm	1200x600x100
A0052810	AIRROCK DD N/RIVESTITO sp. 120 mm	1200x600x120

Airrock HD Fb1

Rock wool, rigid panel with medium density. Covered on one side with black mineral layer to improve aesthetic. For thermal and sound insulation and safety in case of fire.

Size 1000x600 mm. Density 70 kg/m³

$\lambda D = 0.035 \text{ W/mK}$



CODICE ARTICOLO	DESCRIZIONE ARTICOLO	MISURE (mm)
		b x l
A0052824	AIRROCK HD FB1 RIVESTITO sp. 80 mm	1000x600
A0052823	AIRROCK HD FB1 RIVESTITO sp. 140 mm	1000x600
A0052838	AIRROCK HD FB1 RIVESTITO sp. 160 mm	1000x600

Frontrock RP-PT

Rock wool, rigid panel. Non-coated with high density. For thermal and sound insulation. Specific for insulation system.

Size 1000x600 mm.

$\lambda D = 0.039 \text{ W/mK}$



CODICE ARTICOLO	DESCRIZIONE ARTICOLO	MISURE (mm)
		b x l
A0052821	FRONTROCK RP-PT sp. 20 mm	1000x600

Airrock HD ALU

Average-density, rock wool, rigid panel. Covered on one side by a reinforced aluminium sheet and by a mineral fibre net that serves as a steam barrier

for thermal and sound insulator. Size 1450x1000 mm.

Density 70 kg/m³ $\lambda D = 0.035 \text{ W/mK}$



CODICE ARTICOLO	DESCRIZIONE ARTICOLO	MISURE (mm)
		b x l
A0052841	AIRROCK HD ALU RIVESTITO sp. 80 mm	1450x1000
A0052822	AIRROCK HD ALU RIVESTITO sp. 100 mm	1450x1000

Labelrock

Thermal-acoustic, insulating counter-wall, consisting of a rock wool panel (ROCKWOOL) with double density, coupled with a plasterboard sheet with tapered edges, provided with standard sheet, thickness of 10 mm (or 13 mm on request).

Size 1200x2600 mm.

Density of the insulator: density of the upper side 110 kg/m³; density of the lower side 60 kg/m³

$\lambda D = 0.035 \text{ W/mK}$



CODICE ARTICOLO	DESCRIZIONE ARTICOLO	MISURE (mm)
		b x l
A0052853	LABELROCK BA10 sp. 100 mm	1200x2600

Frontrock Max-E

Pannello rigido in lana di roccia non rivestito a doppia densità, per l'isolamento termico ed acustico,

specifico per sistema a cappotto.

Formato 1000x600 mm.

Densità dello strato superiore 155 kg/m³; densità dello strato inferiore 80 kg/m³

$\lambda D = 0,036 \text{ W/mK}$



CODICE ARTICOLO	DESCRIZIONE ARTICOLO	MISURE mm
		b x l
A0052840	FRONTROCK MAX-E 90KG/MC D.D.MQ sp. 50 mm	1000x600
A0052804	FRONTROCK MAX-E 90KG/MC D.D.MQ sp. 60 mm	1000x600
A0023900	FRONTROCK MAX-E 90KG/MC D.D.MQ sp. 70 mm	1000x600
A0023901	FRONTROCK MAX-E 90KG/MC D.D.MQ sp. 80 mm	1000x600
A0023902	FRONTROCK MAX-E 90KG/MC D.D.MQ sp. 100 mm	1000x600
A0023903	FRONTROCK MAX-E 90KG/MC D.D.MQ sp. 120 mm	1000x600
A0023904	FRONTROCK MAX-E 90KG/MC D.D.MQ sp. 140 mm	1000x600
A0023905	FRONTROCK MAX-E 90KG/MC D.D.MQ sp. 160 mm	1000x600
A0023906	FRONTROCK MAX-E 90KG/MC D.D.MQ sp. 180 mm	1000x600
A0023907	FRONTROCK MAX-E 90KG/MC D.D.MQ sp. 200 mm	1000x600

T-Rock 50 N

Rock wool, rigid panel. Non-coated with high density. For thermal and sound insulation.

Size 1200x1000 mm.

$\lambda D = 0,040 \text{ W/mK}$



CODICE ARTICOLO	DESCRIZIONE ARTICOLO	MISURE mm
		b x l
A0023818	ROOFBAC T-ROCK 50 N sp. 30 mm	1200x1000
A0023819	ROOFBAC T-ROCK 50 N sp. 40 mm	1200x1000
A0023820	ROOFBAC T-ROCK 50 N sp. 50 mm	1200x1000
A0023821	ROOFBAC T-ROCK 50 N sp. 60 mm	1200x1000
A0023823	ROOFBAC T-ROCK 50 N sp. 80 mm	1200x1000
A0023825	ROOFBAC T-ROCK 50 N sp. 100 mm	1200x1000

Ceilingrock

Medium-density, rock wool, rigid panel. Exposed side covered with a mineral layer with no aesthetic finishing. Ideal for thermal and sound insulation at the intrados of the first slabs, pilotis, garages and, more generally, areas at risk of fire. Size 1200x1000 mm.

Density 70 kg/m³

$\lambda D = 0.035 \text{ W/mK}$



CODICE ARTICOLO	DESCRIZIONE ARTICOLO	MISURE mm
		b x l
A0052846	CEILINGROCK PANN. RIVESTITO sp. 100 mm	1200x1000

Steprock LD

Rock wool, rigid panel. Non-coated with high density. For subfloors (cement blocks).

Size 1000x600 mm.

Density 100 kg/m³

$\lambda D = 0.036 \text{ W/mK}$



CODICE ARTICOLO	DESCRIZIONE ARTICOLO	MISURE mm
		b x l
A0052805	STEPROCK LD N/RIVESTITO sp. 20 mm	1000x600

211 Compressed panel

Rock wool, semi-rigid panel. Non-coated with medium-low density. For thermal and sound insulation of light parting walls (dry technology) and massive ones.

Size 1200x600 mm. Density 40 kg/m³

$\lambda D = 0.035 \text{ W/mK}$



CODICE ARTICOLO	DESCRIZIONE ARTICOLO	MISURE mm
		b x l
A0023781	211 SEMIRIGIDO sp. 40 mm	1200x600
A0023782	211 SEMIRIGIDO sp. 50 mm	1200x600
A0023783	211 SEMIRIGIDO sp. 60 mm	1200x600
A0023784	211 SEMIRIGIDO sp. 70 mm	1200x600
A0023785	211 SEMIRIGIDO sp. 80 mm	1200x600
A0023787	211 SEMIRIGIDO sp. 100 mm	1200x600
A0052843	211 SEMIRIGIDO sp. 120 mm	1200x600

220 Compressed panel

Rock wool, semi-rigid panel. Non-coated, with medium density. For thermal and sound insulation. Size 1200x600 mm.
Density 50 kg/m³
 $\lambda D = 0.035$ W/mK



CODICE ARTICOLO	DESCRIZIONE ARTICOLO	MISURE mm
		b x l
A0023789	220 SEMIRIGIDO sp. 40 mm	1200x600
A0023790	220 SEMIRIGIDO sp. 50 mm	1200x600
A0023791	220 SEMIRIGIDO sp. 60 mm	1200x600
A0023793	220 SEMIRIGIDO sp. 80 mm	1200x600
A0023795	220 SEMIRIGIDO sp. 100 mm	1200x600

Panel 226

Rock wool, rigid panel. Non-coated, with medium density. For thermal and sound insulation.
Density 60 kg/m³
 $\lambda D = 0.035$ W/mK



CODICE ARTICOLO	DESCRIZIONE ARTICOLO	MISURE mm
		b x l
A0023796	226 RIGIDO sp. 30 mm	1200x600
A0023797	226 RIGIDO sp. 40 mm	1200x600
A0023798	226 RIGIDO sp. 50 mm	1200x600
A0023799	226 RIGIDO sp. 60 mm	1200x600
A0023801	226 RIGIDO sp. 80 mm	1200x600
A0023803	226 RIGIDO sp. 100 mm	1200x600

Acoustic 225 Plus

Rock wool, rigid panel. Non-coated, with medium density. For thermal and sound insulation. Size 1200x600 mm.
Density 70 kg/m³
 $\lambda D = 0.033$ W/mK



CODICE ARTICOLO	DESCRIZIONE ARTICOLO	MISURE mm
		b x l
A0023804	ACOUSTIC 225 PLUS RIGIDO sp. 30 mm	1200x600
A0023805	ACOUSTIC 225 PLUS RIGIDO sp. 40 mm	1200x600
A0023806	ACOUSTIC 225 PLUS RIGIDO sp. 50 mm	1200x600
A0023807	ACOUSTIC 225 PLUS RIGIDO sp. 60 mm	1200x600
A0023808	ACOUSTIC 225 PLUS RIGIDO sp. 70 mm	1200x600
A0023809	ACOUSTIC 225 PLUS RIGIDO sp. 80 mm	1200x600
A0023811	ACOUSTIC 225 PLUS RIGIDO sp. 100 mm	1200x600
A0052839	ACOUSTIC 225 PLUS RIGIDO sp. 140 mm	1200x600

Pannello 234

Non-coated, rock wool, rigid panel, with medium-high density, not load-bearing. For thermal and sound insulation and safety in case of fire.
Size 1200x600 mm.
Density 100 kg/m³
 $\lambda D = 0.035$ W/mK



CODICE ARTICOLO	DESCRIZIONE ARTICOLO	MISURE mm
		b x l
A0023812	234 RIGIDO sp. 30 mm	1200x600
A0023813	234 RIGIDO sp. 40 mm	1200x600
A0023814	234 RIGIDO sp. 50 mm	1200x600
A0023815	234 RIGIDO sp. 60 mm	1200x600
A0023816	234 RIGIDO sp. 80 mm	1200x600
A0023817	234 RIGIDO sp. 100 mm	1200x600
A0052842	234 RIGIDO sp. 120 mm	1200x600



Solutions for insulation in the construction industry

COVERINGS

SHEET COVERING

E60 S
Bac CF Roofine®
Bac CF N Roofine®
Super Bac Roofine®
Isover IBR K 4+
Isover INSULSAFE

FLAT COVERING

Super Bac Roofine®
Super Bac N Roofine®

INDUSTRIAL COVERING

Isover IBR K 4+

WALLS

PERIMETER WALLS

Isover Extrawall 4+
Isover Mupan K 4+
Isover INSULSAFE

BOARD

Capp8

PARTITION WALLS

Isover Extrawall VV 4+
Isover Mupan ALU 4+
Isover Mupan 4+
Isover Par 4+
Isover Calibel SBV 4+

FLOORS

FALSE CEILINGS

Isover Par 4+



You may also like our catalogue
CONSTRUCTION INDUSTRY

You can download it from our website www.idrocentro.com
or you can send an email to info@idrocentro.com



Thermal and sound insulators

E60 S

G3, glass wool panel. Treated with thermosetting resin. Based on organic and plant components. No coverings.



CODICE ARTICOLO	DESCRIZIONE ARTICOLO	MISURE mm
		b x l
A0004126	E60 S sp. 40 mm	1200x600
A0004127	E60 S sp. 50 mm	1200x600
A0004128	E60 S sp. 60 mm	1200x600

SuperBac Roofine® - SuperBac N Roofine®

G3, glass wool panel. Treated with thermosetting resin. Based on organic and plant components. No coverings.



CODICE ARTICOLO	DESCRIZIONE ARTICOLO	MISURE mm
		b x l
A0114139	SUPER BAC ROOFINE sp. 50 mm	1200x1000
A0114140	SUPER BAC ROOFINE sp. 60 mm	1200x1000
A0114141	SUPER BAC ROOFINE sp. 80 mm	1200x1000
A0114142	SUPER BAC ROOFINE sp. 100 mm	1200x1000
A0114143	SUPER BAC ROOFINE sp. 120 mm	1200x1000

CODICE ARTICOLO	DESCRIZIONE ARTICOLO	MISURE mm
		b x l
A0114102	SUPER BAC N ROOFINE sp. 50 mm	1200x1000
A0114136	SUPER BAC N ROOFINE sp. 60 mm	1200x1000
A0114137	SUPER BAC N ROOFINE sp. 80 mm	1200x1000
A0114101	SUPER BAC N ROOFINE sp. 100 mm	1200x1000
A0114138	SUPER BAC N ROOFINE sp. 120 mm	1200x1000

Bac CF Roofine® Bac CF N Roofine®

G3, high-density, glass wool panels. High density, water-repellent. Treated with thermosetting resin based on organic and plant components. Roofine® fibres confer good mechanic resistance. Bac CF Roofine® G3 is covered with a layer of bitumen, with high grammage, reinforced with a glass layer and with a polypropylene film. Bac CF N



CODICE ARTICOLO	DESCRIZIONE ARTICOLO	MISURE mm
		b x l
A0114144	BAC CF ROOFINE sp. 30 mm	1200x1000
A0114145	BAC CF ROOFINE sp. 40 mm	1200x1000
A0114146	BAC CF ROOFINE sp. 50 mm	1200x1000
A0114147	BAC CF ROOFINE sp. 60 mm	1200x1000
A0114148	BAC CF ROOFINE sp. 80 mm	1200x1000
A0114149	BAC CF ROOFINE sp. 100 mm	1200x1000
A0114150	BAC CF ROOFINE sp. 120 mm	1200x1000

CODICE ARTICOLO	DESCRIZIONE ARTICOLO	MISURE mm
		b x l
A0114129	BAC CF N ROOFINE sp. 40 mm	1200x600
A0114130	BAC CF N ROOFINE sp. 50 mm	1200x600
A0114131	BAC CF N ROOFINE sp. 60 mm	1200x600
A0114132	BAC CF N ROOFINE sp. 80 mm	1200x600
A0114133	BAC CF N ROOFINE sp. 100 mm	1200x600
A0114134	BAC CF N ROOFINE sp. 120 mm	1200x600
A0114135	BAC CF N ROOFINE sp. 140 mm	1200x600

Isover INSULSAFE

Glass wool in flakes, white, produced with recycled glass. Without resin. Isover INSULSAFE is compressed in bags and must be mechanically insufflated.



CODICE ARTICOLO	DESCRIZIONE ARTICOLO	MISURE
		kg/sacco
A0114303	INSULSAFE SACCHI	16

Isover IBR K4+

Italian glass wool 4+ felt. Made with a patented binder based on renewable raw materials that improves the quality of indoor air. Covered on one side with bituminous kraft paper.



code description mm

765236 IBR K4+ mm 50 h1200-mq. 16,80 for rol.

CODICE ARTICOLO	DESCRIZIONE ARTICOLO	MISURE mm
		b x l
A0114318	IBR K4+ sp. 200 mm	1200x45000
A0114317	IBR K4+ sp. 180 mm	1200x50000
A0114316	IBR K4+ sp. 160 mm	1200x55000
A0114315	IBR K4+ sp. 140 mm	1200x60000
A0114314	IBR K4+ sp. 120 mm	1200x70000
A0114313	IBR K4+ sp. 100 mm	1200x80000
A0114312	IBR K4+ sp. 80 mm	1200x90000
A0114311	IBR K4+ sp. 60 mm	1200x12000
A0114310	IBR K4+ sp. 50 mm	1200x13000
A0114326	IBR K4+ sp. 180 mm	1000x50000
A0114325	IBR K4+ sp. 160 mm	1000x55000
A0114324	IBR K4+ sp. 140 mm	1000x60000
A0114323	IBR K4+ sp. 120 mm	1000x70000
A0114322	IBR K4+ sp. 100 mm	1000x70000
A0114321	IBR K4+ sp. 80 mm	1000x70000
A0114320	IBR K4+ sp. 60 mm	1000x12000
A0114319	IBR K4+ sp. 50 mm	1000x13000

Isover Par 4+

Italian glass wool 4+ rolled panel, made with a patented binder based on renewable raw materials. It improves the quality of indoor air. The panel is covered on one side by a glass layer.



CODICE ARTICOLO	DESCRIZIONE ARTICOLO	MISURE mm
		b x l
A0114327	PAR 4+ sp. 45 mm	600x1500
A0114328	PAR 4+ sp. 70 mm	600x1000
A0114329	PAR 4+ sp. 95 mm	600x750

Isover Calibel SBV 4+

Counter-walls consisting of an Italian glass wool 4+ panel, made with a patented binder based on renewable raw materials. It improves the quality of indoor air. Glued to a plasterboard sheet. Isover Calibel SBV 4+ has no vapour barrier.



CODICE ARTICOLO	DESCRIZIONE ARTICOLO	MISURE mm
		b x l
A0114386	CONTROPARETE CALIBEL SBV 4+ sp.20+12,5	1200x3000
A0114387	CONTROPARETE CALIBEL SBV 4+ sp.30+12,5	1200x3000
A0114388	CONTROPARETE CALIBEL SBV 4+ sp.40+12,5	1200x3000
A0114389	CONTROPARETE CALIBEL SBV 4+ sp.50+12,5	1200x3000
A0114155	CONTROPARETE CALIBEL SBV 4+ sp.60+12,5	1200x3000
A0114156	CONTROPARETE CALIBEL SBV 4+ sp.80+12,5	1200x3000

Capp8

G3, glass wool panel with high density. Water-repellent. Treated with thermosetting resin. Based on organic and plant components. No coverings.



CODICE ARTICOLO	DESCRIZIONE ARTICOLO	MISURE mm
		b x l
A0004099	CAPP8 sp. 40 mm	600x1200
A0004100	CAPP8 sp. 50 mm	600x1200
A0004101	CAPP8 sp. 60 mm	600x1200
A0004102	CAPP8 sp. 80 mm	600x1200
A0004103	CAPP8 sp. 100 mm	600x1200
A0004104	CAPP8 sp. 120 mm	600x1200
A0114127	CAPP8 sp. 140 mm	600x1200
A0114128	CAPP8 sp. 160 mm	600x1200
A0114215	CAPP8 sp. 180 mm	600x1200
A0114218	CAPP8 sp. 200 mm	600x1200

Isover Mupan K/Isover Mupan K4+

Italian glass wool 4+ panels, made with a patented binder based on renewable raw materials.

It improves the quality of indoor air.

Isover Mupan K 4+ is covered on one side with bituminous kraft paper.

Isover Mupan 4+ is covered on one side with a glass layer.



CODICE ARTICOLO	DESCRIZIONE ARTICOLO	MISURE mm
		b x l
A0114337	MUPAN 4+ sp. 40 mm	600x1450
A0114338	MUPAN 4+ sp. 50 mm	600x1450
A0114339	MUPAN 4+ sp. 60 mm	600x1450
A0114340	MUPAN 4+ sp. 80 mm	600x1450
A0114341	MUPAN 4+ sp. 100 mm	600x1450

CODICE ARTICOLO	DESCRIZIONE ARTICOLO	MISURE mm
		b x l
A0114342	MUPAN K4+ sp. 40 mm	600x1450
A0114343	MUPAN K4+ sp. 50 mm	600x1450
A0114344	MUPAN K4+ sp. 60 mm	600x1450
A0114345	MUPAN K4+ sp. 80 mm	600x1450
A0114346	MUPAN K4+ sp. 100 mm	600x1450
A0114347	MUPAN K4+ sp. 120 mm	600x1450

Isover Extrawall 4+/Isover Extrawall VV 4+

Italian glass wool 4+ felt. Made with a patented binder based on renewable raw materials that improves the quality of indoor air.

Isover Extrawall 4+ is covered on one side with grid aluminium kraft paper; the other side is covered with a glass layer.

Isover Extrawall VV 4+ is covered on both sides with a glass layer.



CODICE ARTICOLO	DESCRIZIONE ARTICOLO	MISURE mm
		b x l
A0114369	EXTRAWALL 4+ sp. 40 mm	1200x2900
A0114370	EXTRAWALL 4+ sp. 50 mm	1200x2900
A0114371	EXTRAWALL 4+ sp. 60 mm	1200x2900
A0114372	EXTRAWALL 4+ sp. 80 mm	1200x2900
A0114373	EXTRAWALL 4+ sp. 100 mm	1200x2900
A0114374	EXTRAWALL 4+ sp. 120 mm	1200x2900

CODICE ARTICOLO	DESCRIZIONE ARTICOLO	MISURE mm
		b x l
A0114375	EXTRAWALL VV 4+ sp. 40 mm	1200x2900
A0114376	EXTRAWALL VV 4+ sp. 50 mm	1200x2900
A0114377	EXTRAWALL VV 4+ sp. 60 mm	1200x2900
A0114378	EXTRAWALL VV 4+ sp. 80 mm	1200x2900
A0114379	EXTRAWALL VV 4+ sp. 100 mm	1200x2900

Thermal and sound insulators

KLOBER

Permo Light

Permo Light is a resistant membrane with 3 layers. It consists of 2 outer protective layers, upper and lower, in UV rays stabilised propylene and of a polyolefin functional membrane.

Application: the special resistant layer, applied on both the upper and lower part, makes for higher mechanical resistance of the membranes placed under the roof/covering/tiles, thus protecting them from damages. Its weight combined with perfect hydrophobising reflect the high-quality technical features that set Permo Light apart.



code	description
58350	Permolight KU0043-04

Elements for roof ventilation

Why roofs need to be ventilated

In warm weather, temperatures can easily reach up to 80° C between the insulation and the roof covering. The hot air spreads to the rooms beneath the roof, negatively affecting the room temperature. In the cold and humid winter months, the external (cold) air meets the internal (warm) air in the cavity between the insulation and the roof covering causing condensation. Only correct air circulation where air enters through the eaves and escapes at ridge level can resolve this problem and prolong the life of your roof.

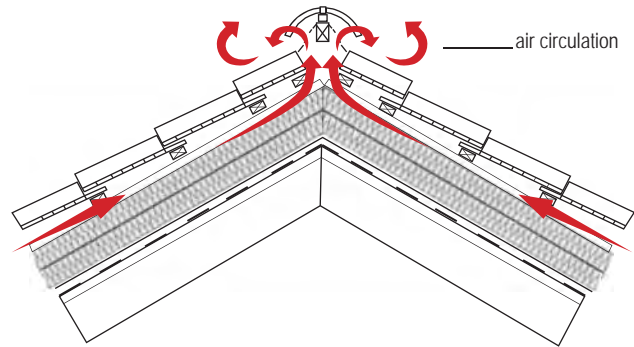

Roof ridge

Uni-Venti Roll

Venti Roll is the sealing-ventilation tape to be used on sloping and level roof ridges. The PP geotextile is used, which has special UV stabilizing additives, due to which the product durability is guaranteed for minimum 10 years after the roof covering.

Size (width) 240 mm, 310 mm, 360 mm, 390 mm

Thickness of the aluminium 140µ

UV stabilization

One material: polypropylene (PP)

Air permeability 280 g/m²

Density of butyl glue 1,7 g/m³

Standard width of butyl glue 15 mm - 40 mm +/- 1mm

Minimum installation temperature + 5 °C

Temperature resistance from -30 °C to + 80 °C

Water permeability 5 g /m² /24h

Colours RAL 9005, RAL 8019, RAL 8015, RAL 8004, RAL 7021, RAL 1001



Uni-Venti Roll ALU 150 mmUn

Is a ventilating and sealing tape for use on sloping and horizontal ridges. It is made of single-layer lacquered aluminum strip, UV resistant. The use of special vents provides protection from rain and insects. The tape can be used to bituminous covers, shingles and metal sheet roofing tiles.

Size (width) 150 mm

Thickness of the aluminum 140 µ

UV stabilization

Material: aluminum

Air permeability 250 g/m²

Density of butyl glue 1,7 g/m³

Standard width of butyl glue 15 mm +/- 1 mm

Minimum installation temperature + 5 °C

Temperature resistance from -30 °C to + 80 °C

Colours RAL 9005, RAL 8019, RAL 8015, RAL 8004, RAL 7021, RAL 1001



Uni-Classic Roll

Sealing-ventilation tape to be used on sloping and level roof ridges. The PP geotextile is used, which has special UV stabilizing additives, due to which the product durability is guaranteed for minimum 10 years after the roof covering.

Size (width) 310 mm, 360mm, 390 mm
Thickness of the aluminum 140 µ
UV stabilization
One material: polypropylene (PP)
Air permeability 280 g/m ²
Density of butyl glue 1,7 g/m ³
Standard width of butyl glue 15 mm - 40 mm +/- 1mm
Minimum installation temperature + 5 °C
Temperature resistance from -30 °C to + 80 °C
Water permeability 5 g /m ² /24h
Colours RAL 9005, RAL 8019, RAL 8015, RAL 8004, RAL 7021, RAL 1001



Uni-BL support

BL support is entirely made of galvanized steel, it is used as fastening element of roof ridge batten, ensures easy and stable assembly.

Height: 210 mm
Width: 40 mm, 50 mm
Material: stainless steel
Thickness of the metal sheets : 800 µ



Chimney

Uni-Flex met ALU 3D

Is a professional tape used for sealing and roof flashings. Due to 3D embossment technology there is a possibility to use the tape in difficult confined places on the roof. It is made of lacquered UV resistant aluminum strip of high weather resistance.

Size (width) 300 mm, 390 mm
Length 5000 mm, 2500 mm
Thickness of the aluminum 140 µ
UV stabilization
Material : aluminum
Density of butyl glue 1,7 g/m ³
Width of butyl glue 290 mm +/- 1 mm
Thickness of butyl glue 1,0 mm +/- 1 mm
Minimum installation temperature + 5 °C
Colours RAL 9005, RAL 8019, RAL 8015, RAL 8004, RAL 7021, RAL 1001
Temperature resistance from -30 °C to + 80 °C
Flexibility 100 %

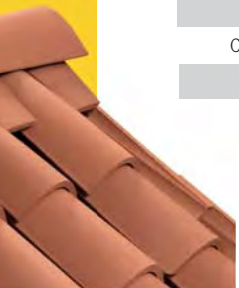

Roof drains

For conventional roof drainage systems Unimetal provides solutions for nearly every kind of roof construction. Different constructions, layer compositions and roof functions ask for varied drain combinations.

Sectional drawings

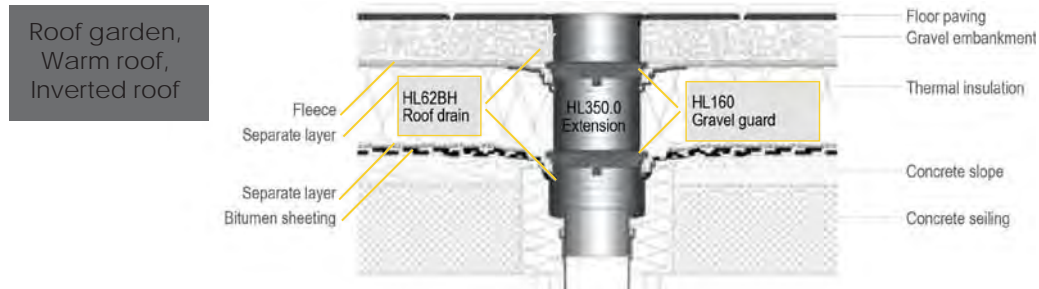

Products

- Standard roof drain vertical/ horizontal with clamp ring
- Roof drain vertical/ horizontal with bitumen membrane
- Roof drain vertical with PVC-flange
- Roof drain vertical/ horizontal with PP-flange



Safety drain for roofs

Generally the rainwater that accumulates on the roofs is discharged through gutters, if the amount of rain exceeds however the annual average, it will no longer be guaranteed a proper drainage of rainwater. In this case, a safety drain can be installed, to make reliable the tightness of the roof and the drainage of rainwater.

Excess rain is safely discharged. The safety drain includes exceptional events such as that of excess rain not provided for and protects the roof structure.

Sectional drawings



Products

- Safety drain for roofs standard vertical with clamp ring
- Safety drain for roofs vertical with bitumen membrane
- Safety drain for roofs vertical/ horizontal with PVC-flange
- Safety drain for roofs vertical/ horizontal with PP-flange

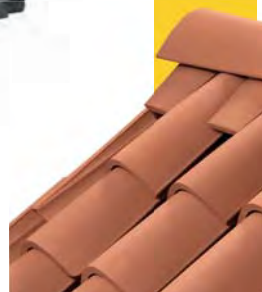

Balcony and terrace drains

In general the draining of rain water on terrace and balcony surfaces should happen with gullies. To avoid leakage in the structure, it is important, to take care of the kind of waterproofing, especially the connection between drain and the local waterproofing.

Sectional drawings

Terrace, slabs fit into gravel bed without heating

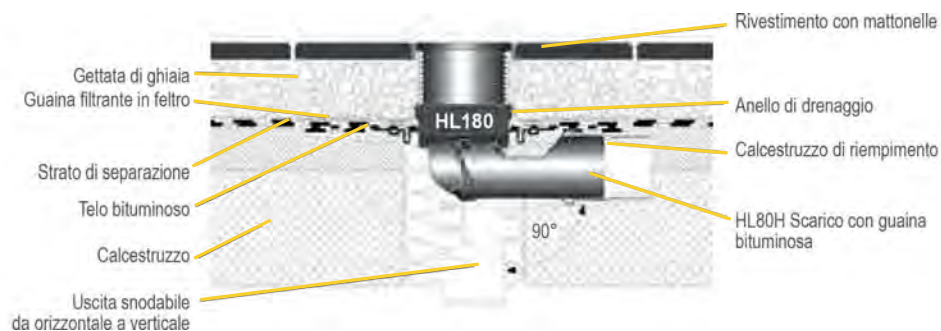

Products

- Standard drain
- Standard drain with bitumen flange
- Drain with polymer concrete flange
- Drain horizontal with high capacity
- Drain horizontal with high capacity and bitumen flange



METAL SYSTEMS



Gutters
Frontispieces and gutters
Rain drainage pipes
Terminals
Examples of shape
Weight Kg/m per surface

Gutters

Round thickness 0,6 mm



code	surface cm	A cm
0004.X	20	10,0
0010.X	25	13,0
0013.X	28	14,0
0016.X	30	16,0
0019.X	33	18,0

Shaped thickness 0,6 mm



code	surface cm	A cm
0052.X	25	10,0
0058.X	30	15,5
0061.X	33	17,0

Square thickness 0,6 mm

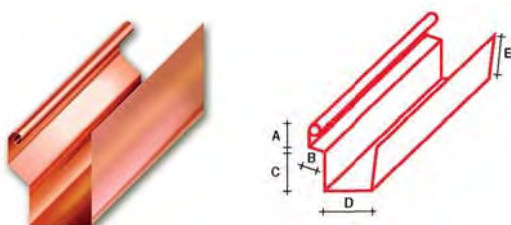

code	surface cm	A	B	C	D	E	F
0078.X	30						
0082.X	33	3,0	2,0	5,5	10,0	9,5	3

Square thickness 0,6 mm

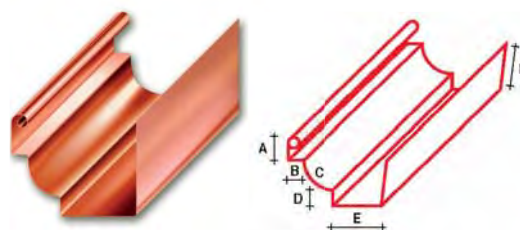

code	surface cm	A	B	C	D	E	F	G
00085.X	40	3,0	2,0	8,5	2,0	10,0	11,5	3

Frontispieces and gutters

Straight frontispiece thickness 0,6 mm

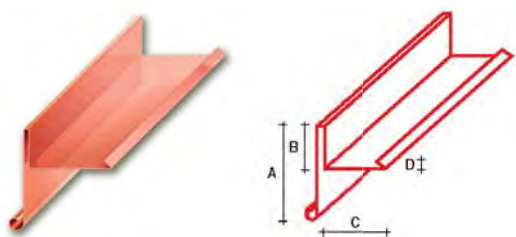

code	surface cm	A	B	C	D	E
1025.X	40	16,0	6,0	13,0	2,0	3,0

Shifted frontispiece thickness 0,6 mm

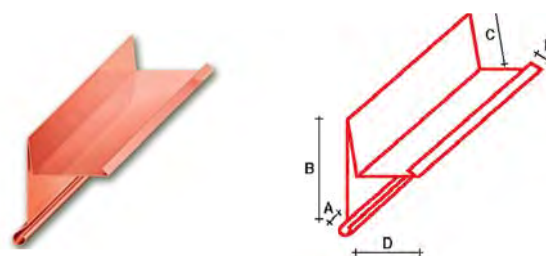

code	surface cm	A	B	C	D	E	F
1075.X	40	3,0	13,0	6,0	13,0	2,0	3
1078.X	45	3,5	17,0	6,0	13,5	2,0	3

L-shaped gutter - under tile thickness 0,6 mm

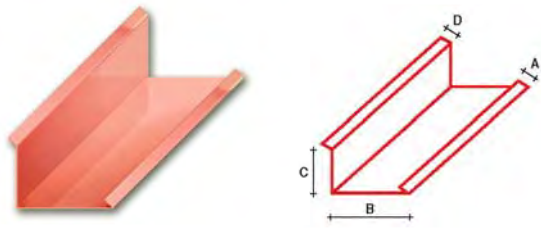

code	surface cm	A	B	C	D
1119.X	33	2,0	16,0	13,0	2,0
1125.X	40	2,0	20,0	16,0	2,0

L-shaped gutter - over tile thickness 0,6 mm

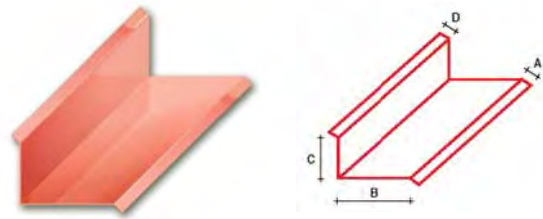

code	surface cm	A	B	C	D
1146.X	33	2,0	16,0	13,0	2,0
1149.X	40	2,0	20,0	16,0	2,0

V-shaped gutter thickness 0,6 mm

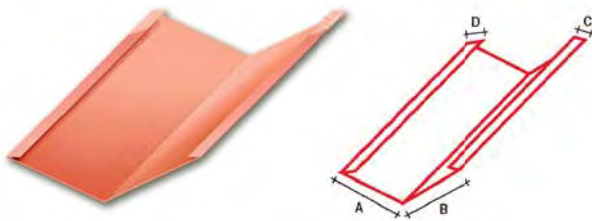

code	surface cm	A	B	C	D
1173.X	50	23,0	23,0	2,0	2,0

*Copper, stainless steel, galvanised and pre-painted versions available

Rain drainage pipes

Square standing seam thickness 0,6 mm

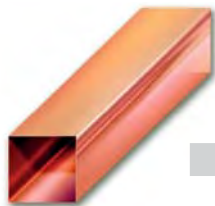

code	mmxmm	length mt.
0132.X	80x80	4
0134.X	100x100	4

Electrowelded in copper and st. steel



code		section mm Ø	length mt.
0136.X		60	2
01461	copper	60	2
01097080	alucopper	60	2
0137.X		80	4
01371	copper	80	4
0138.X		100	4
01381	copper	100	4
0143.X		120	4
01431	copper	120	4
01392	copper-st.steel	80	4
01402	copper-st.steel	100	4

Round-standing seam thickness 0,6 mm



**Dark brown version available, white, grey, other colours on request.

code		section mm Ø	length mt.
0112.X		80**	4
01121	copper	80**	4
01137060	alucopper	80**	4
0114.X		100	4
01141	copper	100	4
01150080	alucopper	100	4
		100	4
0116.X		120	4
0117080	alucopper	120	4

*Copper, stainless steel, galvanised and pre-painted versions available

If you want to place an order, replace the "X" of the code with the number corresponding to the chosen material. X= 1 COPPER, 2 STAINLESS STEEL, 3 GALVANISED, 4 PRE-PAINTED

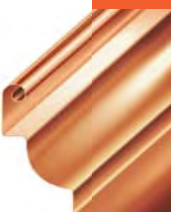

Terminals

Square straight thickness 1 mm

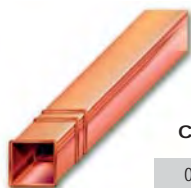

code	mmxmm	length mt.
0648.X	80x80	1
0650.X	80x80	1,5
0652.X	80x80	2
0654.X	100x100	1
0656.X	100x100	1,5
0658.X	100x100	2

Square with elbow thickness 1 mm



code	mmxmm	length mt.
0634.X	80x80	1
0636.X	80x80	1,5
0638.X	80x80	2
0640.X	100x100	1
0642.X	100x100	1,5
0644.X	100x100	2

Round straight



code	section mm Ø	length mt.
0618.X	80	1
0620.X	80	1,5
0622.X	80	2
0624.X	100	1
0626.X	100	1,5
0628.X	100	2
0629.X	120	1,5
0630.X	120	2
0631.X	120	1

Round with elbow



code	section mm Ø	length mt.
0602.X	80	1
0604.X	80	1,5
0606.X	80	2
0610.X	100	1
0612.X	100	1,5
0614.X	100	2
0616.X	120	2

Straight cast iron



code	section mm Ø	length mt.
06760	80	1
06780	80	1,5
06800	80	2
06840	100	1
06860	100	1,5
06880	100	2
06920	125	1,5
06940	125	2
06965	150	2

With cast iron elbow



code	section mm Ø	length mt.
06620	80	1
06640	80	1,5
06660	80	2
06680	100	1
06700	100	1,5
06720	100	2
06735	125	1,5
06740	125	2

*Copper, stainless steel, galvanised and pre-painted versions available.

Examples of shapes

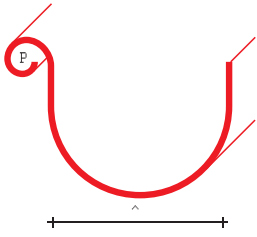

round

surf.	20	25	28	30	33	40
A	9,5	13	14	15	16,5	20

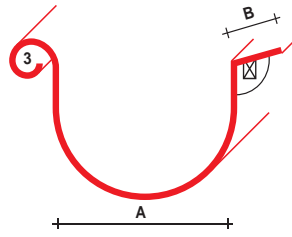

round w/ flaps

surf.	25	30	33	35	40	45
A	9,5	13	14	15	16,5	20
B	5	5	5	5	7	5

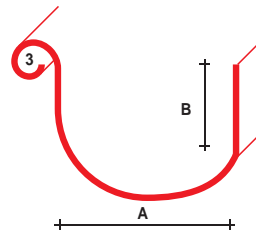

round2

surf.	30	33	40	45	50
A	13	14	17	21	23
B	8	9	11	12	14

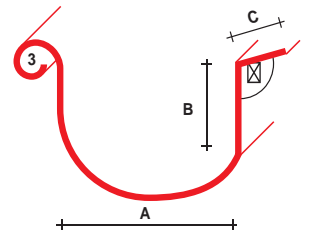

round2 w/ flap

surf.	35	40	45	50
A	13	14	17	21
B	8	9	11	12
C	5	7	5	5

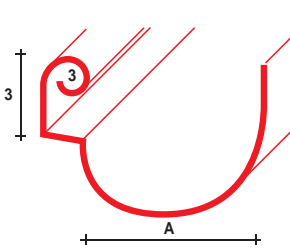

shaped c/ int.

surf.	25	30	33	35	40
A	13,5	17	18	19	21

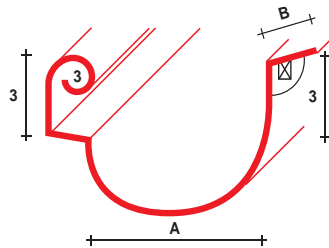

shaped c/ int. w/ flaps

surf.	30	33	40	45
A	13,5	17	18	21
B	5	5	7	5

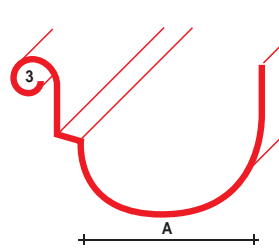

shaped c/ ext

surf.	25	30	33	35	40
A	13,5	17	18	19	21

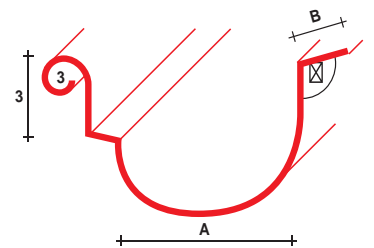

shaped c/ ext. w / flap

svil.	30	33	35	40
A	13,5	17	18	21

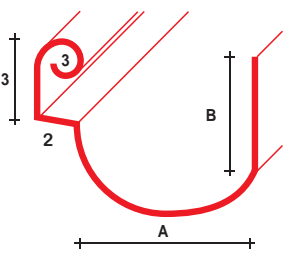

shaped c/ int

svil.	30	33	40	45
A	15	17	21	23,5
B	7	8	11	13,5

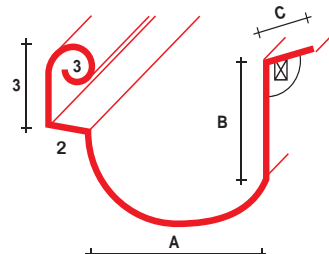

shaped2 c/ int. w / flaps

svil.	35	40	45	50
A	15	17,5	21	23,5
B	7	9,5	11	13,5
C	5	5	5	5

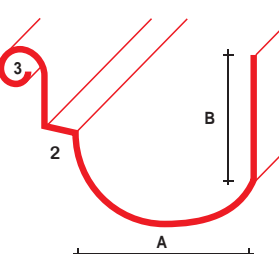

shaped2 c/ ext.

svil.	30	33	40	45
A	14,5	17	20,5	23,5
B	7,5	8	11,5	13,5

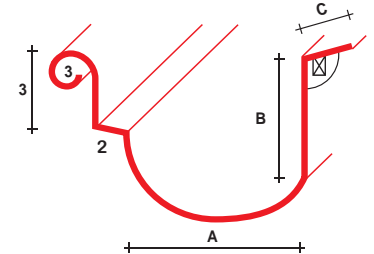

shaped2 c/ ext. w /flap

svil.	35	40	45	50
A	15	17,5	21	23,5
B	7	9,5	11	13,5
C	5	5	5	5

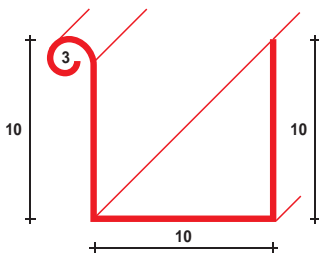

01 surf. 33

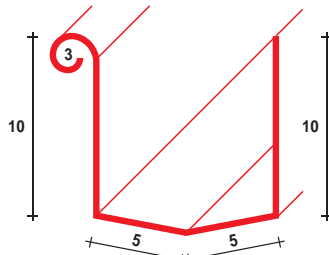

02 surf. 33

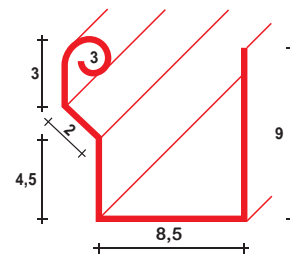

03 surf. 30

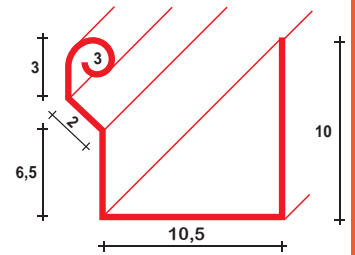

04 surf. 35



Examples of shapes

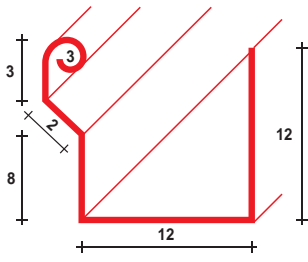

05 surf. 40

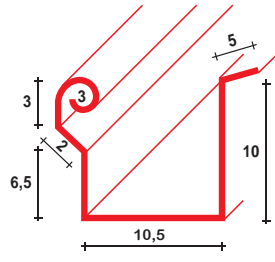

06 surf. 40

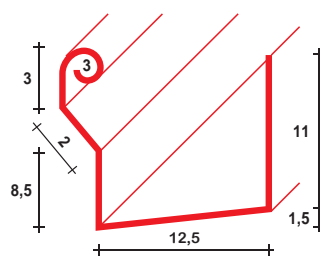

07 surf. 40

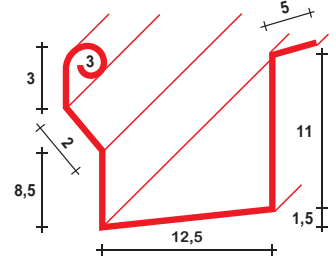

08 surf. 45

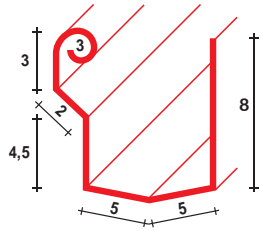

09 surf. 30

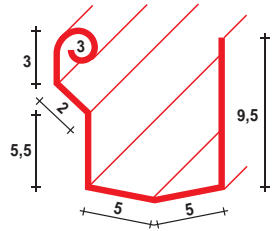

10 surf. 33

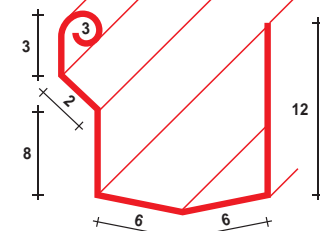

11 surf. 40

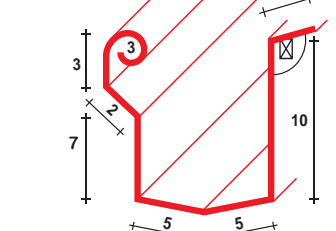

12 surf. 40 (*specify angle)

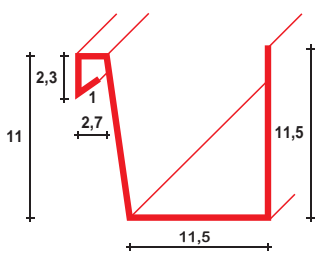

13 surf. 40

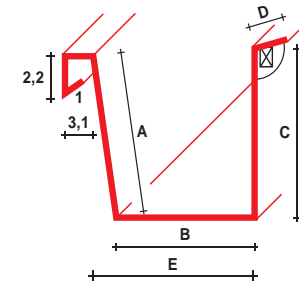

14 measures on request (*specify angle)

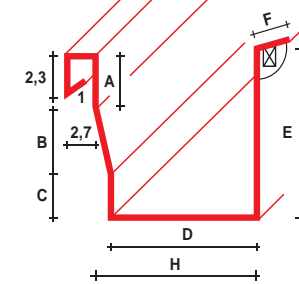

15 measures on request

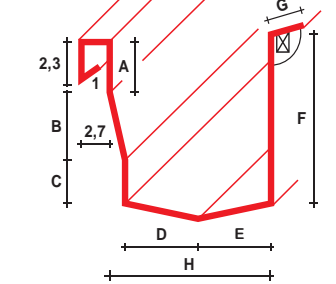

16 measures on request (*specify angle)

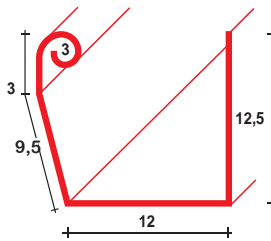

17 surf. 40

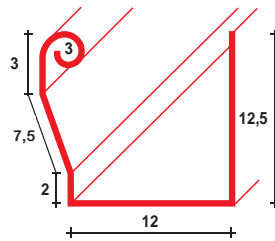

18 surf. 40

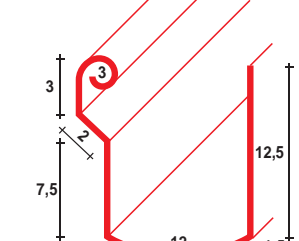

19 surf. 40

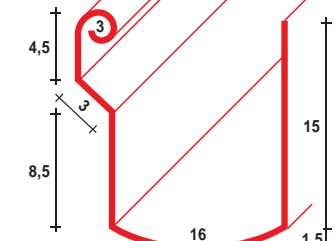

20 surf. 50

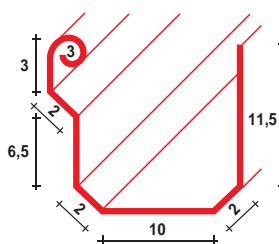

21 surf. 40

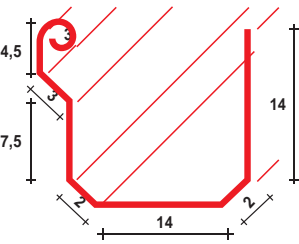

22 surf. 50

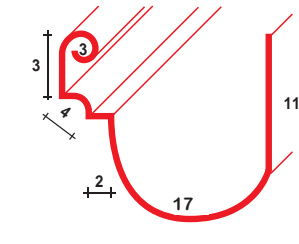

23 surf. 40

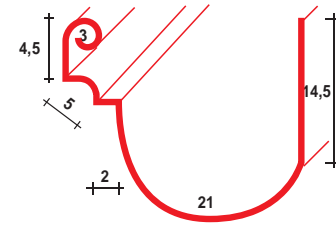

24 surf. 50

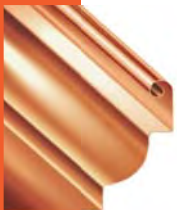

Examples of shapes

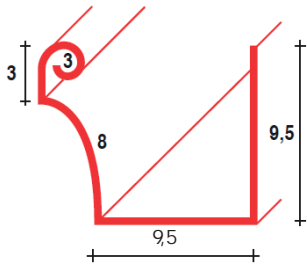

25 surf. 33

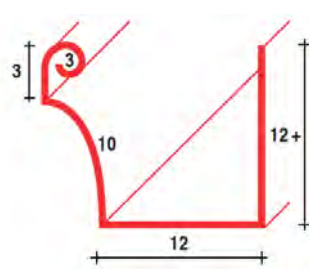

26 surf. 40

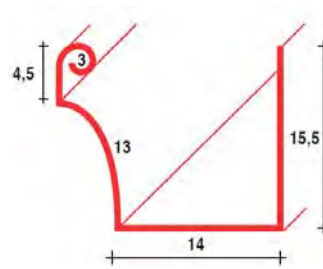

27 surf. 50

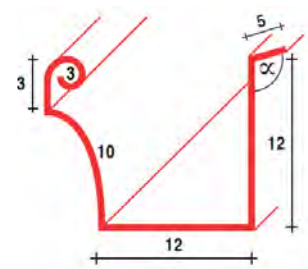

28 surf. 45 (x specify angle)

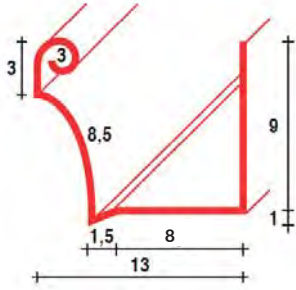

29 surf. 33

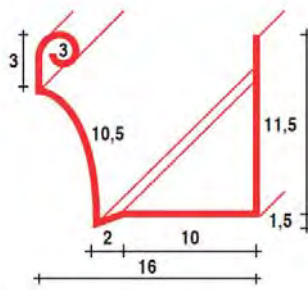

30 surf. 40

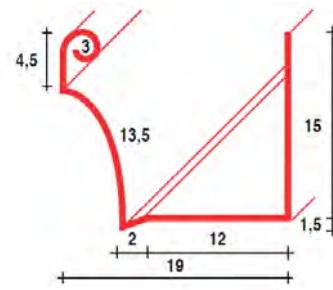

31 surf. 50

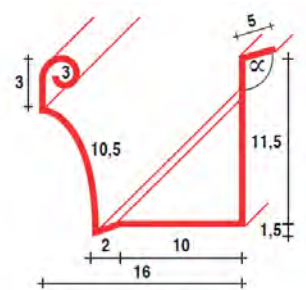

32 surf. 45 (x specify angle)

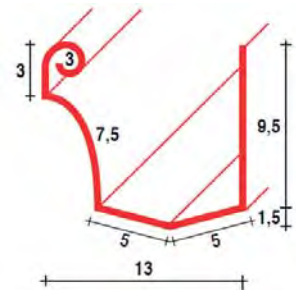

33 surf. 33

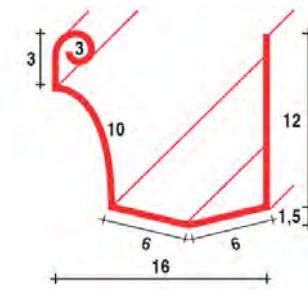

34 surf. 40

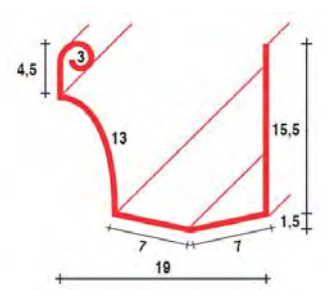

35 surf. 50

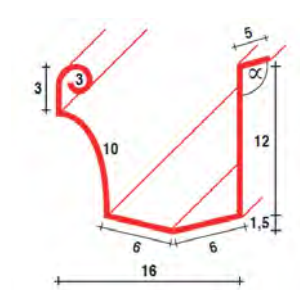

36 surf. 45 (x specify angle)

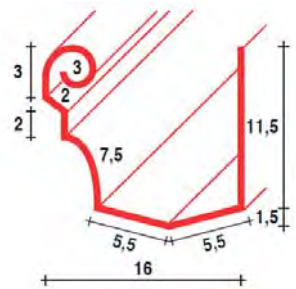

37 surf. 40

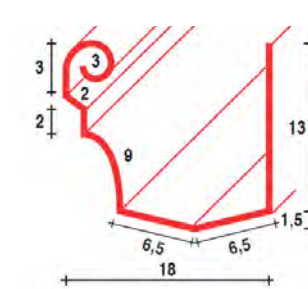

38 surf. 45

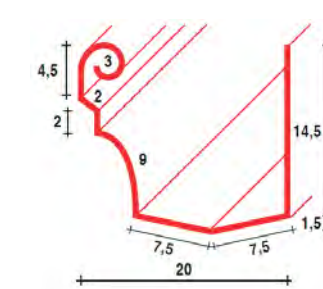

39 surf. 40

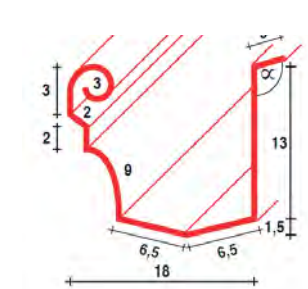

40 surf. 50 (x specify angle)

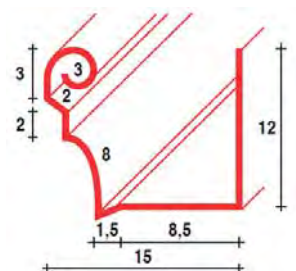

41 surf. 40

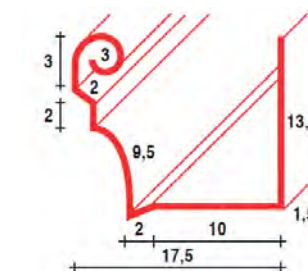

42 surf. 45

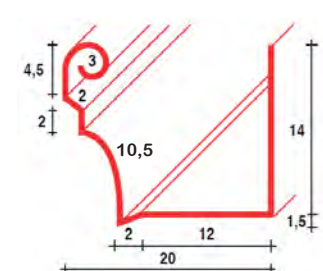

43 surf. 50

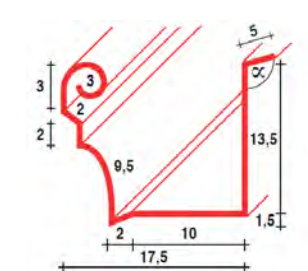

44 surf. 50 (x specify angle)

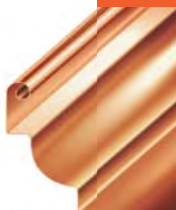

Examples of shapes

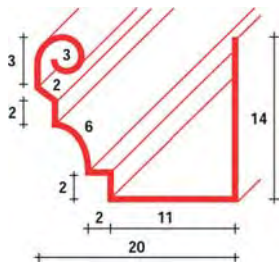

45 surf. 45

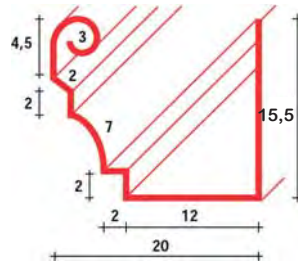

46 surf. 50

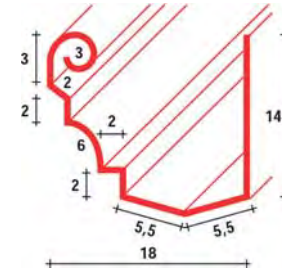

47 surf. 45

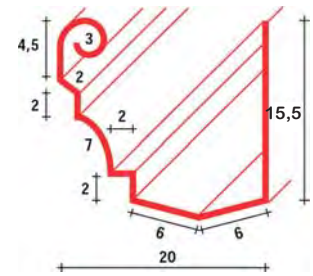

48 surf. 50

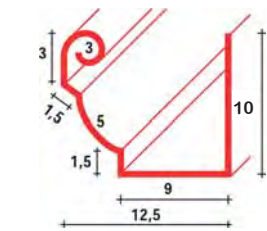

49 surf. 33

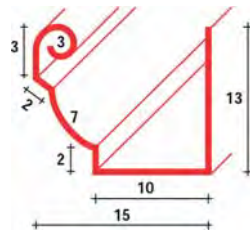

50 surf. 40

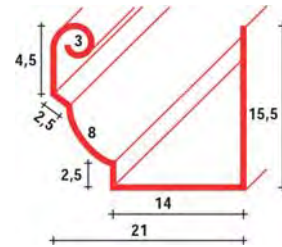

51 surf. 50

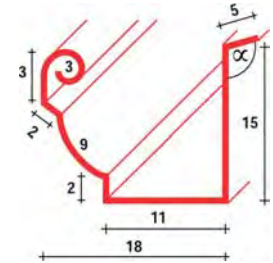

52 surf. 50

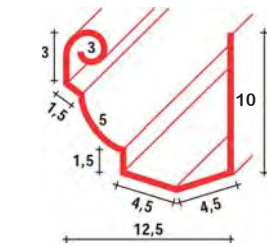

53 surf. 33

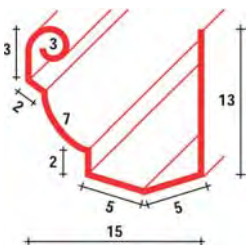

54 surf. 40

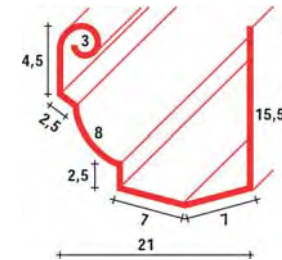

55 surf. 50

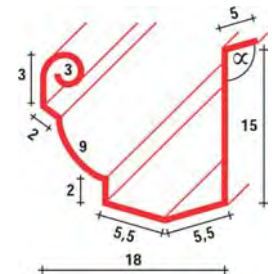

56 surf. 50

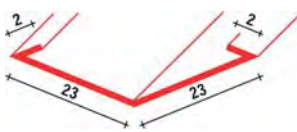

57 surf. 50

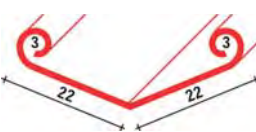

58 surf. 50

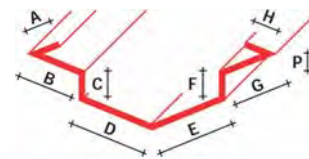

59 measures on request

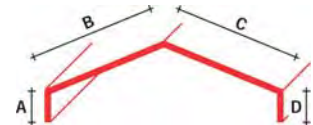

60 measures on request

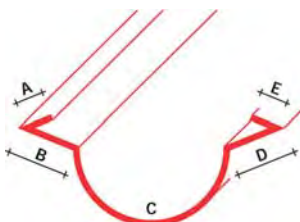

61 measures on request

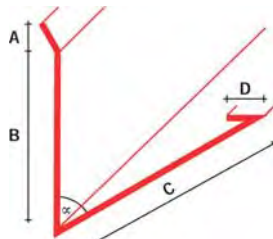

62 measures on request
(x=specify angle)

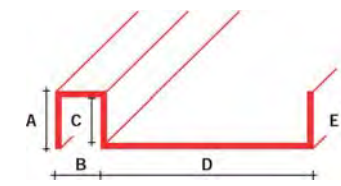

63 measures on request

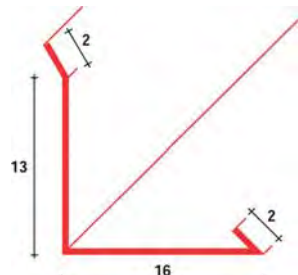

64 surf. 33 series



Examples of shapes

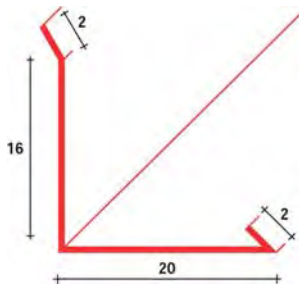

65 surf. 40 series

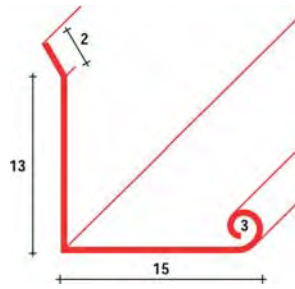

66 surf. 33 series

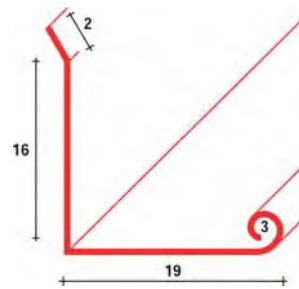

67 surf. 40

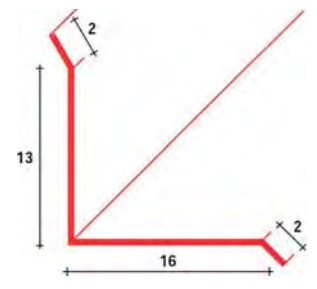

68 surf. 33 series

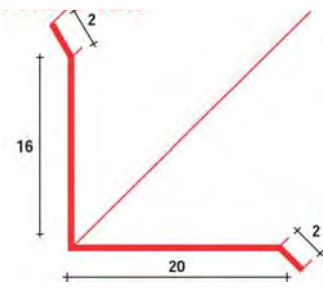

69 surf. 40 series

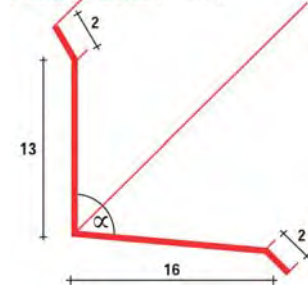

70 surf. 33 series (x=110°)

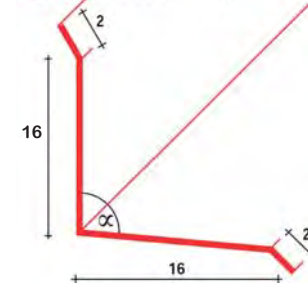

71 surf. 40 (x= specify angle)

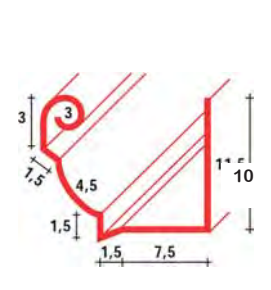

72 surf. 33

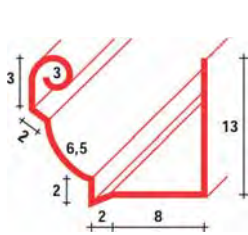

73 surf. 40

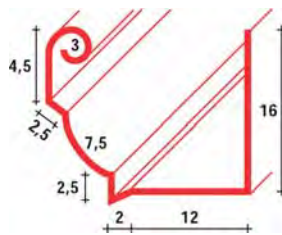

74 surf. 50

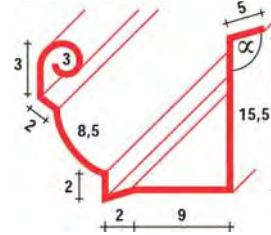

75 surf. 50 (x= specify angle)

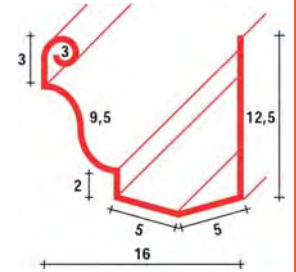

76 surf. 40

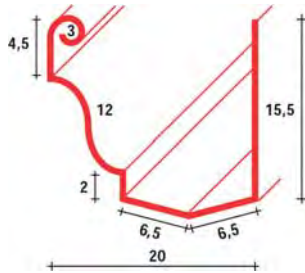

77 surf. 50

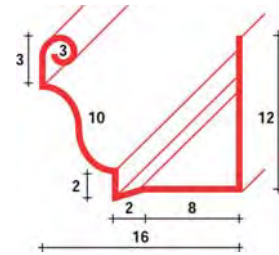

78 surf. 40

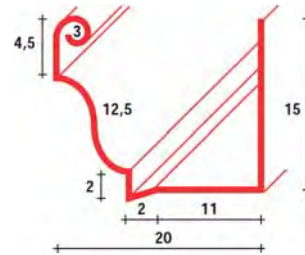

79 surf. 50

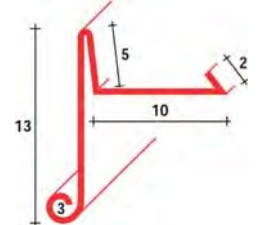

80 surf. 33

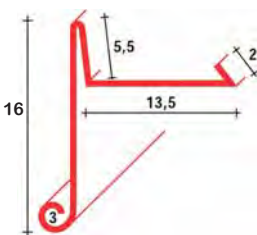

81 surf. 40 series

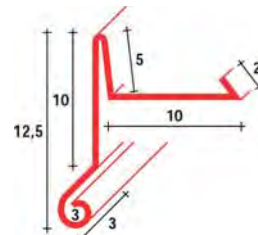

82 surf. 33

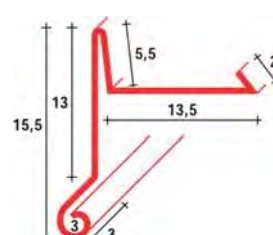

83 surf. 40 series

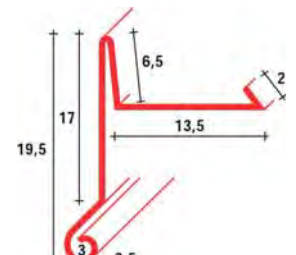

84 surf. 45

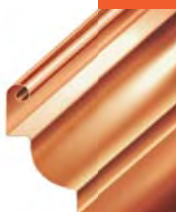

Examples of shapes

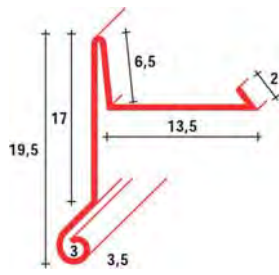

85 surf. 50 series

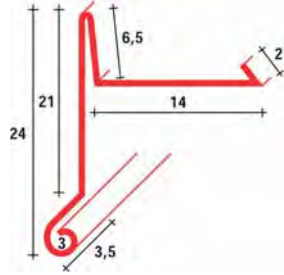

85 surf. 50 series

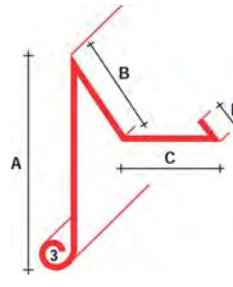

86 measures on request

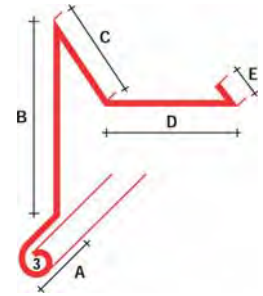

87 measures on request

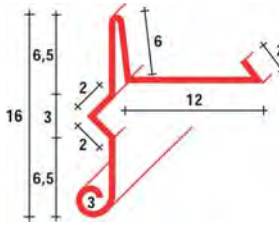

88 surf. 40

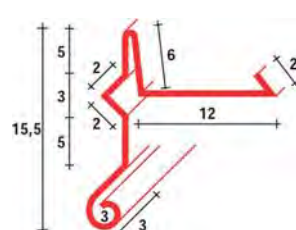

89 surf. 40

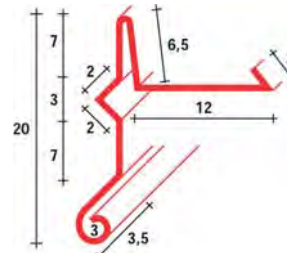

90 surf. 45

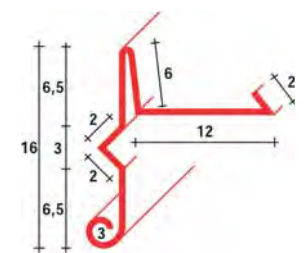

91 surf. 40

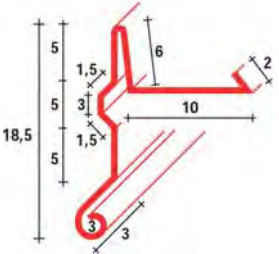

92 surf. 40

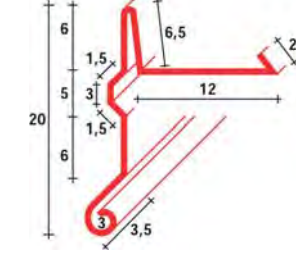

93 surf. 45

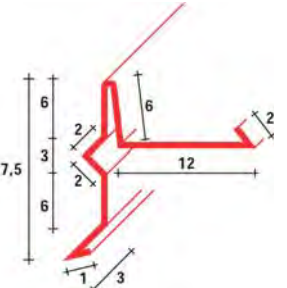

94 surf. 40

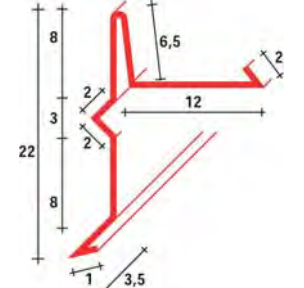

95 surf. 45

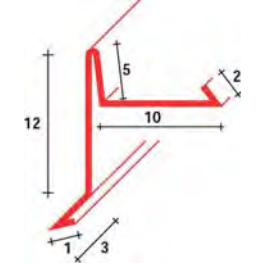

96 surf. 33

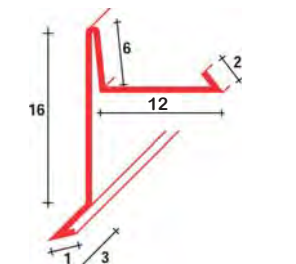

97 surf. 40

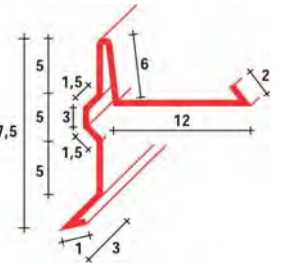

98 surf. 40

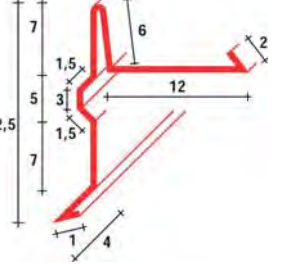

99 surf. 45

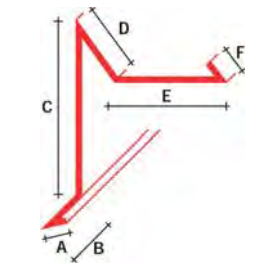

100 measures on request

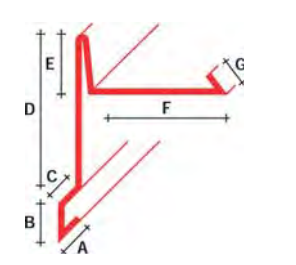

101 measures on request

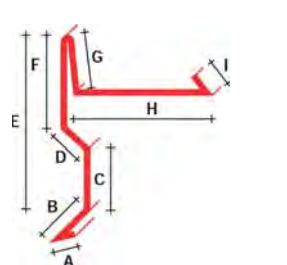

102 measures on request

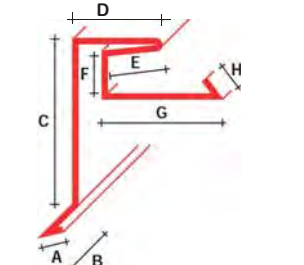

103 measures on request



Examples of shapes

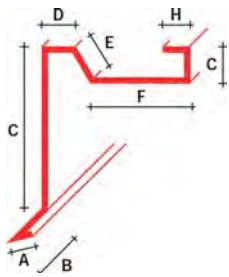

104 measures on request

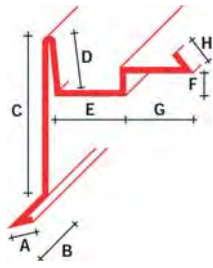

105 measures on request

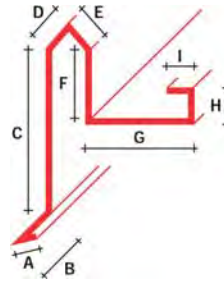

106 measures on request

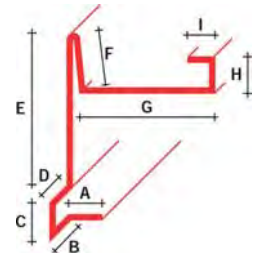

107 measures on request

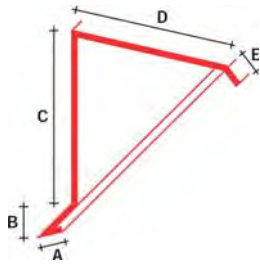

108 measures on request

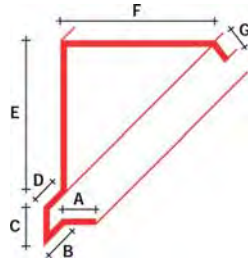

109 measures on request

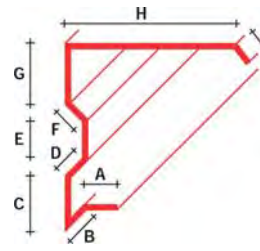

110 measures on request

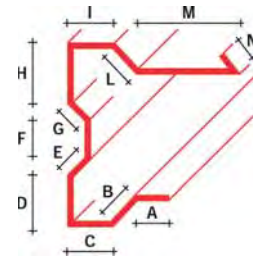

112 measures on request

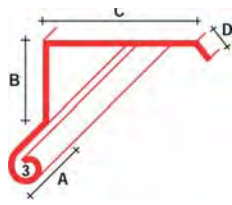

113 measures on request

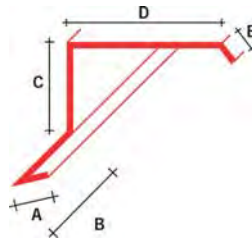

114 measures on request

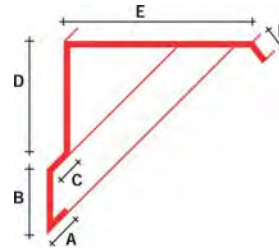

115 measures on request

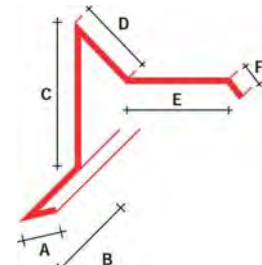

116 measures on request

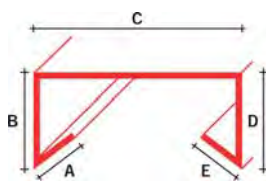

117 measures on request

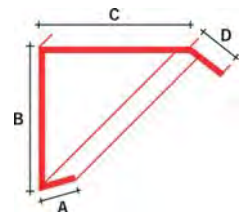

118 measures on request

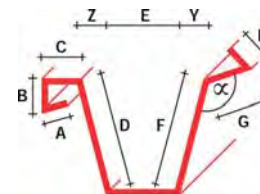

119 measures on request
(x=specify angle)

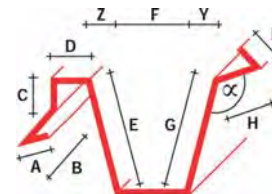

120 measures on request
(x=specify angle)

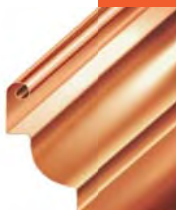

Weight Kg/m per surface

galvanised and pre-painted steel

thickness		surface					pipes		weight
		25	30	33	40	50	Ø 8	Ø 10	Kg/m ²
5/10	Kg/m	0,97	1,17	1,29	1,56	1,95	-	-	3,90
6/10	Kg/m	1,18	1,41	1,56	1,88	2,35	1,28	1,60	4,70
8/10	Kg/m	1,57	1,88	2,07	2,50	3,13	1,69	2,02	6,25
10/10	Kg/m	1,97	2,36	2,59	3,14	3,93	-	-	7,85
15/10	Kg/m								11,77

copper

thickness		surface					pipes		weight
		25	30	33	40	50	Ø 8	Ø 10	Kg/m ²
5/10	Kg/m	1,11	1,34	1,47	1,78	2,23	1,20	-	4,45
5,5/10	Kg/m	1,22	1,47	1,62	1,96	2,45	1,24	1,54	4,90
6/10	Kg/m	1,34	1,60	1,78	2,14	2,67	1,34	1,68	5,34
7/10	Kg/m	1,56	1,87	2,08	2,50	3,12	1,56	1,96	6,23
7,5/10	Kg/m	1,68	2,00	2,23	2,68	3,34	1,68	2,10	6,68
8/10	Kg/m	1,78	2,14	2,35	2,85	3,56	1,79	2,24	7,12
10/10	Kg/m	2,22	2,68	2,93	3,56	4,45	-	-	8,89

aluminium / alucopper

thickness		surface					pipes		weight
		25	30	33	40	50	Ø 8	Ø 10	Kg/m ²
7/10	Kg/m	0,47	0,57	0,62	0,75	0,94	-	-	1,89
8/10	Kg/m	0,54	0,65	0,71	0,86	1,08	-	-	2,16
1	Kg/m	0,67	0,81	0,89	1,08	1,35	-	-	2,70

stainless steel / copper stainless steel

thickness		surface					pipes		weight
		25	30	33	40	50	Ø 8	Ø 10	Kg/m ²
5/10	Kg/m	1,00	1,20	1,32	1,60	2,00	1,10	1,35	4,00
6/10	Kg/m	1,20	1,44	1,59	1,92	2,40	1,21	1,51	4,80
8/10	Kg/m	1,60	1,92	2,12	2,56	3,20	-	-	6,40
10/10	Kg/m	2,00	2,40	2,64	3,20	4,00	-	-	8,00

Rheinzink

thickness		surface					pipes		weight
		25	30	33	40	50	Ø 8	Ø 10	Kg/m ²
7/10	Kg/m	1,26	1,51	1,68	2,02	2,52	1,26	1,57	5,04
8/10	Kg/m	1,44	1,73	1,92	2,30	2,88	1,46	1,88	5,76
10/10	Kg/m	1,80	2,16	2,40	2,88	3,60	1,81	2,26	7,20

lead

thickness	10/10	12/10	15/10	20/10	30/10	40/10
Kg/m	12	14,5	18	24	36	48

bronze aluminium

thickness		surface					pipes		weight
		25	30	33	40	50	Ø 8	Ø 10	Kg/m ²
7/10	Kg/m	0,47	0,57	0,62	0,75	0,94	-	-	1,89
8/10	Kg/m	0,54	0,65	0,71	0,86	1,08	-	-	2,16
1	Kg/m	0,67	0,81	0,89	1,08	1,35	-	-	2,70

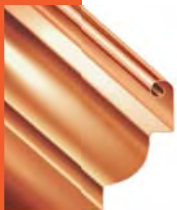

METAL SYSTEMS ACCESSORIES



Hip rafters
Headers and rods
Gutter-brackets and gutter-hangers
Drain holes, reducers and pipe elbows
Various accessories
Collars and dowels
Pivots and spacers
Ornaments
Tile-holders, wire and snow guards
Adjustable gutters
Expansion joints and special parts
Pipes and lead accessories
Consumables
Materials for coverings

Hip rafters

Round curled externally



code	surface cm
0202.X	25
0204.X	28
0206.X	30
0208.X	33

AVAILABLE IN THE FOLLOWING MATERIALS
 copper st.steel galvanised pre-painted alucopper
 X X X X

Round curled internally



code	surface cm
0213.X	20
0214.X	25
0216.X	28
0218.X	30
0220.X	33

AVAILABLE IN THE FOLLOWING MATERIALS
 copper st.steel galvanised pre-painted alucopper
 X X X X

Shaped curled externally



code	surface cm
0228.X	25
0229.X	28*
0230.X	30
0232.X	33
0234.X	40

* only copper

AVAILABLE IN THE FOLLOWING MATERIALS
 copper st.steel galvanised pre-painted alucopper
 X X X X

Shaped curled internally



code	surface cm
0240.X	25
0241.X	28*
0242.X	30
0244.X	33
0246.X	40

* only copper

AVAILABLE IN THE FOLLOWING MATERIALS
 copper st.steel galvanised pre-painted alucopper
 X X X X

Square curled externally (on request)

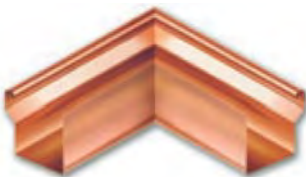

code	surface cm
0252.X	33
0254.X	40

AVAILABLE IN THE FOLLOWING MATERIALS
 copper st.steel galvanised pre-painted alucopper
 X X X X

Square curled internally (on request)



code	surface cm
0260.X	33*
0262.X	40

* pre-painted version also available

AVAILABLE IN THE FOLLOWING MATERIALS
 copper st.steel galvanised pre-painted alucopper
 X X X X

Upward for round and shaped gutter (on request)



code
0264.X

AVAILABLE IN THE FOLLOWING MATERIALS
 copper st.steel galvanised pre-painted
 X X



Headers

For round gutter



code	surface cm
0268.X	20*
0270.X	25
0272.X	28
0274.X	30
0276.X	33

* only copper/pre-painted

AVAILABLE IN THE FOLLOWING MATERIALS
 copper st.steel galvanised pre-painted alucopper
 X X X X X

For shaped gutter



code	surface cm
0282.X	30 right
0284.X	30 left
0286.X	33 right
0288.X	33 left

AVAILABLE IN THE FOLLOWING MATERIALS
 copper st.steel galvanised pre-painted alucopper
 X X X X X

For Swiss "convex" gutter



code	surface cm
0290.X	25
0291.X	30
0292.X	33

AVAILABLE IN THE FOLLOWING MATERIALS
 copper st.steel galvanised pre-painted alucopper
 X

Rods

Curled externally for round gutter 25x2 mm



code	surface cm
2054.X	30
2056.X	35
2058.X	40
2060.X	45
2062.X	50

AVAILABLE IN THE FOLLOWING MATERIALS
 copper st.steel galvanised pre-painted alucopper
 X X X X

Curled internally for shaped and square gutter 25x2 mm



code	surface cm
2072.X	30
2074.X	35
2076.X	40
2078.X	45
2080.X	50

AVAILABLE IN THE FOLLOWING MATERIALS
 copper st.steel galvanised pre-painted alucopper
 X X X X

Curled big 25x2 mm



code	surface cm
2066.X	30
2067.X	35
2068.X	40

AVAILABLE IN THE FOLLOWING MATERIALS
 copper st.steel galvanised pre-painted alucopper
 X X X

Curled big heavy 20x5 mm



code	surface cm
2088.X	40

AVAILABLE IN THE FOLLOWING MATERIALS
 copper st.steel galvanised pre-painted alucopper
 X

If you want to place an order, replace the "X" of the code with the number corresponding to the chosen material. X= 1 COPPER, 2 STAINLESS STEEL, 3 GALVANISED, 4 PRE-PAINTED 69 ALUCOPPER

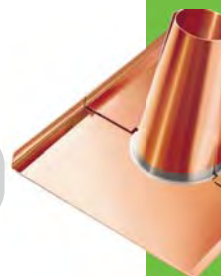

Curled big ribbed 20x2 mm



code surface cm

2040.X	40
--------	----

AVAILABLE IN THE FOLLOWING MATERIALS
 copper st.steel galvanised pre-painted alucopper
 X X X X

Ribbed with slot 25x1,2x40 mm



code surface cm

2093.X	40
--------	----

AVAILABLE IN THE FOLLOWING MATERIALS
 copper st.steel galvanised pre-painted alucopper
 X X X X

Wedge Type



codice surface cm

1980.X	30
1981.X	35
1982.X	40
1983.X	45

AVAILABLE IN THE FOLLOWING MATERIALS
 copper st.steel galvanised pre-painted alucopper
 X X X X

Gutter-brackets

Round 25x2 mm



code surface cm

for 25 round gutter	
2006.X	35
2008.X	40
2010.X	45
2012.X	50
2014.X	55
for 28 round gutter	
1997.X	40
1998.X	45
1999.X	50
for 30 round gutter	
2009.X	40
2011.X	45
2013.X	50
2015.X	55

AVAILABLE IN THE FOLLOWING MATERIALS
 copper st.steel galvanised pre-painted alucopper
 X X X X

Shaped 25x2mm



code surface cm

2019.X	50
--------	----

AVAILABLE IN THE FOLLOWING MATERIALS
 copper st.steel galvanised pre-painted alucopper
 X X X X

Gutter-hangers

Shaped with bend or tip 20x5 mm



code surface cm

2034.X	25
2035.X	30
2036.X	33

AVAILABLE IN THE FOLLOWING MATERIALS
 copper st.steel galvanised pre-painted alucopper
 X X X X

Shaped with curl 20x5 mm



code surface cm

20341.X	25
20351.X	30
20361.X	33

AVAILABLE IN THE FOLLOWING MATERIALS
 copper st.steel galvanised pre-painted alucopper
 X X X X

Round with bend or tip and step 20x5 mm



code	surface cm
2049.X	25
2050.X	30
2051.X	33

AVAILABLE IN THE FOLLOWING MATERIALS
 copper st.steel galvanised pre-painted alucopper
 X X X X

Round with bend or tip 20x5 mm



code	surface cm
20492.X	25
20502.X	30
20512.X	33

AVAILABLE IN THE FOLLOWING MATERIALS
 copper st.steel galvanised pre-painted alucopper
 X X X X

Round with tip and step 20x5 mm



code	surface cm
20491.X	25
20501.X	30
20511.X	33

AVAILABLE IN THE FOLLOWING MATERIALS
 copper st.steel galvanised pre-painted alucopper
 X X X X

Round with curl 20x5 mm



code	surface cm
20490.X	25
20500.X	30
20510.X	33

AVAILABLE IN THE FOLLOWING MATERIALS
 copper st.steel galvanised pre-painted alucopper
 X X X X

Swiss type extra type 25x5 mm



code	surface cm
2046.X	25
2047.X	28
2048.X	33
2044.X	40*

* not available in st. steel

AVAILABLE IN THE FOLLOWING MATERIALS
 copper st.steel galvanised pre-painted alucopper
 X X X X

Bracket type ribbed gutter-hanger with rod 25x2 mm for round version



code	surface cm
20321.X	30
20331.X	33

code	description
1940069	support with alucopper support 25/28/33

AVAILABLE IN THE FOLLOWING MATERIALS
 copper st.steel galvanised pre-painted alucopper
 X X X X

Bracket type ribbed gutter-hanger with rod for shaped version



code	surface cm
2038.X	30
2039.X	33

AVAILABLE IN THE FOLLOWING MATERIALS
 copper st.steel galvanised pre-painted alucopper
 X X X X

If you want to place an order, replace the "X" of the code with the number corresponding to the chosen material. X= 1 COPPER, 2 STAINLESS STEEL, 3 GALVANISED, 4 PRE-PAINTED



Drain holes

Shaped round drain hole



code	section Ø mm
0400.X	60
0402.X	80
0404.X	100
0406.X	120

AVAILABLE IN THE FOLLOWING MATERIALS
 copper st.steel galvanised pre-painted alucopper
 X X X X X

Flat round drain hole



code	section Ø mm
0410.X	60
0412.X	80
0414X	100
0416.X	120

AVAILABLE IN THE FOLLOWING MATERIALS
 copper st.steel galvanised pre-painted alucopper
 X X X X X

Flat square drain hole



code	section Ø mm
0422.X	80x80
0424.X	100x100

AVAILABLE IN THE FOLLOWING MATERIALS
 copper st.steel galvanised pre-painted alucopper
 X X X X

Swiss drain hole



code	section Ø mm
0430.X	60/25
04322.X	80/25
04344.X	100/25
0432.X	80/33
0434.X	100/33

AVAILABLE IN THE FOLLOWING MATERIALS
 copper st.steel galvanised pre-painted alucopper
 X X X X X

Shaped conical drain hole



codice	section Ø mm	height cm
0442.X	80	15
0444.X	100	15
0446.X	120*	15

* not available in st. steel

AVAILABLE IN THE FOLLOWING MATERIALS
 copper st.steel galvanised pre-painted alucopper
 X X X X

Flat conical drain hole



codice	section Ø mm	height cm
0452.X	80	15
0454.X	100	15
0456.X	120	15

AVAILABLE IN THE FOLLOWING MATERIALS
 copper st.steel galvanised pre-painted alucopper
 X X X X

Cup



code	section Ø mm
04621	80
04641	100

AVAILABLE IN THE FOLLOWING MATERIALS
 copper st.steel galvanised pre-painted alucopper
 X



Reducers

Reducer



code	size mm	
0471.X	100/80 80/60	copper and st.steel
0472.X	100/120	copper
0473.X	80x80/80	copper
0474.X	100x100/100	copper
0475.X	100x100/80	copper

AVAILABLE IN THE FOLLOWING MATERIALS
copper st.steel galvanised pre-painted alucopper

X X

Increaser



code	size mm
0476.X	80/100 60/80
0477.X	60/80

AVAILABLE IN THE FOLLOWING MATERIALS
copper st.steel galvanised pre-painted alucopper

X

Barrel



code	section mm
2295.X	80
2296.X	100

AVAILABLE IN THE FOLLOWING MATERIALS
copper st.steel galvanised pre-painted alucopper

X

Pipe elbow

Round - standing seam



code	section Ø mm	
0305.X	60	open
0307.X	80	open
0301.X	80	closed
0309.X	100	open
0303.X	100	closed

AVAILABLE IN THE FOLLOWING MATERIALS
copper st.steel galvanised pre-painted alucopper

X X X X X

Electro-welded EU-ROUND 6/10 mm



code		
030211.X	shift	Ø 80 mm 40°
032211.X	open	Ø 80 mm 72°
031211.X	closed	Ø 80 mm 85°
030411.X	shift	Ø 100 mm 4°
032411.X	open	Ø 100 mm 72°
031411.X	closed	Ø 100 mm 85°

AVAILABLE IN THE FOLLOWING MATERIALS
copper st.steel galvanised pre-painted alucopper

X X X X

Square - standing seam



code	section mm	
0336.X	80x80	open*
0332.X	80x80	closed
0338.X	100x100	open
0334.X	100x100	closed

* stainless steel also

AVAILABLE IN THE FOLLOWING MATERIALS
copper st.steel galvanised pre-painted alucopper

X X X

Square electro-welded

code	section mm
0356.X	80x80 open
0357.X	100x100 open

AVAILABLE IN THE FOLLOWING MATERIALS
copper st.steel galvanised pre-painted alucopper

X X X X

If you want to place an order, replace the "X" of the code with the number corresponding to the chosen material. X= 1 COPPER, 2 STAINLESS STEEL, 3 GALVANISED, 4 PRE-PAINTED, 15, RHEINZINK, 69 ALUCOPPER

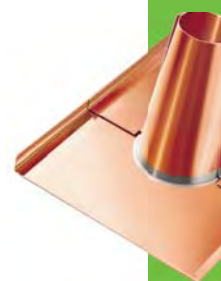

Volute 3 sectors



code	section Ø mm
0349.X	60*
0340.X	80
0341.X	100
034111	120**

* Copper and st. steel versions available
 ** only copper version available

AVAILABLE IN THE FOLLOWING MATERIALS
 copper st. steel galvanised pre-painted alucopper
 X X X X

Edged volute 3 sectors



code	section Ø mm
0378.X	80
0379.X	100

AVAILABLE IN THE FOLLOWING MATERIALS
 copper st. steel galvanised pre-painted alucopper
 X

Volute 5 sectors

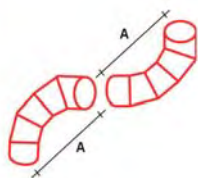

code	section Ø mm
0342.X	80
0344.X	100
0345.X	120

AVAILABLE IN THE FOLLOWING MATERIALS
 copper st. steel galvanised pre-painted alucopper
 X X X

Extendable volute with sectors and dropping system



code	section Ø mm
0374.X	80 mm - 80 cm
0375.X	100 mm - 80 cm
0373.X	100 mm - 60 cm

AVAILABLE IN THE FOLLOWING MATERIALS
 copper st. steel galvanised pre-painted alucopper
 X X X

Volute with pattern (on request)



Various accessories

Connecting pipe



code section Ø mm

0353.X 60

0352.X 80

0354.X 100

0358.X 120*

* on request

AVAILABLE IN THE FOLLOWING MATERIALS

copper st.steel galvanised pre-painted alucopper

X X X X X

Reduced connecting pipe



code section Ø mm

0370.X 80/60*

0371.X 100/80**

0372.X 120/100

037211.X 120/60-80

* st. steel version also available
** pre-painted and st. steel versions available

AVAILABLE IN THE FOLLOWING MATERIALS

copper st.steel galvanised pre-painted alucopper

X

Tee (87° c. pipe)



code section Ø mm

0359.X 60

0350.X 80

0351.X 100*

0360.X 120*

* pre-painted version also available

AVAILABLE IN THE FOLLOWING MATERIALS

copper st.steel galvanised pre-painted alucopper

X X

Centric or symmetrical basin



code section Ø mm

0504.X 80

0506.X 100

AVAILABLE IN THE FOLLOWING MATERIALS

copper st.steel galvanised pre-painted alucopper

X X X X X

Eccentric basin



code section Ø mm

0510.X 80

0512.X 100

0513.X 120

AVAILABLE IN THE FOLLOWING MATERIALS

copper st.steel galvanised pre-painted alucopper

X X X X X

Extra funnel Palermo type (small)



code section Ø mm

0523.X 80

0524.X 100

0525.X 120

AVAILABLE IN THE FOLLOWING MATERIALS

copper st.steel galvanised pre-painted alucopper

X X X X X

Extra funnel Catania type (big)



code section Ø mm

0526.X 80

0527.X 100

0528.X 120

AVAILABLE IN THE FOLLOWING MATERIALS

copper st.steel galvanised pre-painted alucopper

X X X X X

German extra funnel



code section Ø mm

0520.X 80

0521.X 100

0522.X 120

AVAILABLE IN THE FOLLOWING MATERIALS

copper st.steel galvanised pre-painted alucopper

X

If you want to place an order, replace the "X" of the code with the number corresponding to the chosen material. X= 1 COPPER, 2 STAINLESS STEEL, 3 GALVANISED, 4 PRE-PAINTED, 15, RHEINZINK, 69 ALUCOPPER



Diverter - decanting pipe



code section Ø mm

0722.X	80
0724.X	100

AVAILABLE IN THE FOLLOWING MATERIALS
 copper st.steel galvanised pre-painted alucopper
 X X X

Inspectionable decanting pipe



code section Ø mm

0458.X	80	connection
0459.X	100	connection
0460.X	120	connection
07222.X	80	decanter
07244.X	100	decanter
07255.X	120	decanter

AVAILABLE IN THE FOLLOWING MATERIALS
 copper st.steel galvanised pre-painted alucopper
 X X

Chain holder Mottalciata type (water shoot)



code section Ø mm

0717.X	60
0718.X	80
0719.X	100

AVAILABLE IN THE FOLLOWING MATERIALS
 copper st.steel galvanised pre-painted alucopper
 X

Snake



code section Ø mm

2355.X	40
2356.X	60*
2357.X	80
2358.X	100

* also available in the prepainted version

AVAILABLE IN THE FOLLOWING MATERIALS
 copper st.steel galvanised pre-painted alucopper
 X X

Lion's mouth/Dragon



code section Ø mm

2342.X	40*
2344.X	60
2346.X	80
2348.X	100

* only copper and st. steel versions available

AVAILABLE IN THE FOLLOWING MATERIALS
 copper st.steel galvanised pre-painted alucopper
 X X X X

Snake



code section Ø mm

23422.X	40
23444.X	60

AVAILABLE IN THE FOLLOWING MATERIALS
 copper st.steel galvanised pre-painted alucopper
 X X X X

Lion's mouth with sectors



code section Ø mm

23451	60*
-------	-----

AVAILABLE IN THE FOLLOWING MATERIALS
 copper st.steel galvanised pre-painted alucopper
 X

Wrought collar covering



code section Ø mm

2307.X	80
2308.X	100

AVAILABLE IN THE FOLLOWING MATERIALS
 copper st.steel galvanised pre-painted alucopper
 X

Double buckle (joined or separated)



code	section Ø mm
2301.X	60
2302.X	80
2304.X	100
2305.X	120

AVAILABLE IN THE FOLLOWING MATERIALS
 copper st.steel galvanised pre-painted alucopper
 X X X X X

Wheel



code	section Ø mm
2310.X	60
2312.X	80
2314.X	100
2316.X	120*

* galvanised version not available

AVAILABLE IN THE FOLLOWING MATERIALS
 copper st.steel galvanised pre-painted alucopper
 X X X X X

Ventilation round grids



code	section Ø mm	
0731.X	80*	griare 1
0732.X	100	griare 2
0733.X	120	griare 3
0734.X	140	griare 4
0735.X	150	griare 5
0736.X	160	
0737.X	180	
0738.X	200	griare 6

* st. steel version also available

AVAILABLE IN THE FOLLOWING MATERIALS
 copper st.steel galvanised pre-painted alucopper
 X

Square ventilation grids



code	size mm
0739.X	140X140
0740.X	140X250
0741.X	150X150
0743.X	200X200
0744.X	230X230
0742.X	270X150

AVAILABLE IN THE FOLLOWING MATERIALS
 copper st.steel galvanised pre-painted alucopper
 X

Drainer



code	section Ø mm
0702.X	80*
0704.X	100
0703.X	120

* only copper version available

AVAILABLE IN THE FOLLOWING MATERIALS
 copper st.steel galvanised pre-painted alucopper
 X X X X X

Bent and straight water-spreading device



code	section Ø mm
0712.X	60*
0714.X	80
0716.X	100
0715.X	120**

* only copper and galvanised versions available
 ** only copper and st. steel versions available

AVAILABLE IN THE FOLLOWING MATERIALS
 copper st.steel galvanised pre-painted alucopper
 X X X X X

Leaves grid



code
0822.X

AVAILABLE IN THE FOLLOWING MATERIALS
 copper st.steel galvanised pre-painted alucopper
 X X X

If you want to place an order, replace the "X" of the code with the number corresponding to the chosen material. X= 1 COPPER, 2 STAINLESS STEEL, 3 GALVANISED, 4 PRE-PAINTED, 15, RHEINZINK, 69 ALUCOPPER



Collars and dowels

Round extra collar



code	section Ø mm
2111.X	60*
2112.X	80
2114.X	100
2116.X	120
2118.X	140
2119.X	150
2120.X	160**

* galvanised version not available
** only st. steel and galvanised versions available

AVAILABLE IN THE FOLLOWING MATERIALS				
copper	st.steel	galvanised	pre-painted	alucopper
X	X	X	X	X

Square extra collar



code	size mm
2122.X	80X80
2124.X	100X100

AVAILABLE IN THE FOLLOWING MATERIALS			
copper	st.steel	galvanised	pre-painted alucopper
X	X	X	X

Short round dowel A = 30-50 mm flap



code	section Ø mm
2220.X	60*
2222.X	80
2224.X	100**

* only st. steel and galvanised versions available
**galvanised version not available

AVAILABLE IN THE FOLLOWING MATERIALS				
copper	st.steel	galvanised	pre-painted	alucopper
X	X	X	X	X

Short square dowel A = 50 mm flap



code	size mm
2232.X	80X80
2234.X	100X100

AVAILABLE IN THE FOLLOWING MATERIALS			
copper	st.steel	galvanised	pre-painted alucopper
X	X	X	X

Round decorated dowel A = 120 mm Motta type



code	section Ø mm
2267.X	60*
2268.X	80
2269.X	100

* only copper version available

AVAILABLE IN THE FOLLOWING MATERIALS				
copper	st.steel	galvanised	pre-painted	alucopper
X	X			

Square decorated dowel A = 120 mm



code	size mm
2272.X	80X80
2274.X	100X100

AVAILABLE IN THE FOLLOWING MATERIALS				
copper	st.steel	galvanised	pre-painted	alucopper
X	X	X	X	X

Heavy collar 200x50 mm - 4 curls



code	section Ø mm
21051.X	80
21061.X	100
21071.X	120

AVAILABLE IN THE FOLLOWING MATERIALS				
copper	st.steel	galvanised	pre-painted	alucopper
X				

Heavy collar 4 dec. curls



code	section Ø mm
21081.X	100
21091.X	120

AVAILABLE IN THE FOLLOWING MATERIALS				
copper	st.steel	galvanised	pre-painted	alucopper
X				

Collar for cast iron terminals



code	section Ø mm	
21403	80	black galvanised
21413	100	black galvanised
21423	120/125	galvanised

AVAILABLE IN THE FOLLOWING MATERIALS
copper st.steel galvanised pre-painted alucopper

X

Clamp with bush



code	section Ø mm
2604.X	80/100

AVAILABLE IN THE FOLLOWING MATERIALS
copper st.steel galvanised pre-painted alucopper

X X X

Cast iron dowel (without clamp)



code
22800

AVAILABLE IN THE FOLLOWING MATERIALS
copper st.steel galvanised pre-painted alucopper c.iron

X

Pivots - Spacers

Pivot

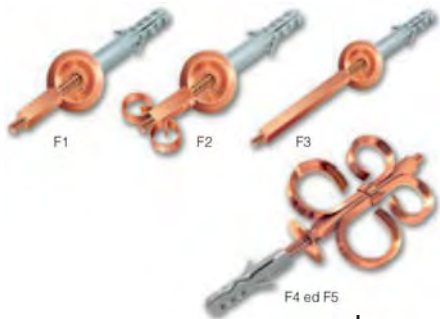

code	size mm
2276.X F1	50
2279.X F2	decorated 50*
2280.X F3	120
2278.X F4	decorated 160**
2281.X F5	decorated 160
2282.X F5	decorated 180***

* pre-painted version also available
** pre-painted and galvanised versions also available
*** only copper version available

AVAILABLE IN THE FOLLOWING MATERIALS
copper st.steel galvanised pre-painted alucopper

X X

Coppered brass spacer



code	size mm
21320	20
21340	30
21360	40
21380	50

Galvanised spacer



code	size mm
21323	20
21343	30
21363	40
21383	50

If you want to place an order, replace the "X" of the code with the number corresponding to the chosen material. X= 1 COPPER, 2 STAINLESS STEEL, 3 GALVANISED, 4 PRE-PAINTED, 15, RHEINZINK, 69 ALUCOPPER

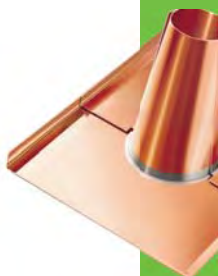

Decorations

Stars



code

23251

AVAILABLE IN THE FOLLOWING MATERIALS
copper st.steel galvanised pre-painted alucopper

X

Decorations for angle of our own production



code

2330.X

AVAILABLE IN THE FOLLOWING MATERIALS
copper st.steel galvanised pre-painted alucopper

X

X

X

X

Decorations for angle with curls



code

2331.X

AVAILABLE IN THE FOLLOWING MATERIALS
copper st.steel galvanised pre-painted alucopper

X

X

Lily-like decorations for angle



code

2332.X

AVAILABLE IN THE FOLLOWING MATERIALS
copper st.steel galvanised pre-painted alucopper

X

X

Leaf

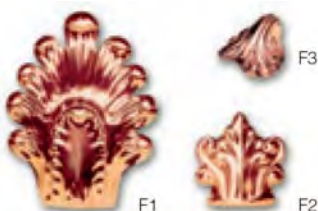

code

size

F1 2352.X big

F2 2354.X small

F3 23501 type 2

AVAILABLE IN THE FOLLOWING MATERIALS
copper st.steel galvanised pre-painted alucopper

X

Big stud for collar



code

23091.X

AVAILABLE IN THE FOLLOWING MATERIALS
copper st.steel galvanised pre-painted alucopper

X

Stud



code

2320.X

AVAILABLE IN THE FOLLOWING MATERIALS
copper st.steel galvanised pre-painted alucopper

X

X

X

X

X

Bored stud



code

2322.X

AVAILABLE IN THE FOLLOWING MATERIALS
copper st.steel galvanised pre-painted alucopper

X

X

X

X

X



Stamped chain



code

2603.X

AVAILABLE IN THE FOLLOWING MATERIALS
copper st.steel galvanised pre-painted alucopper

X

Chain



code

2602.X round
2601.X oval

AVAILABLE IN THE FOLLOWING MATERIALS
copper st.steel galvanised pre-painted alucopper

X X

Copper wind vane

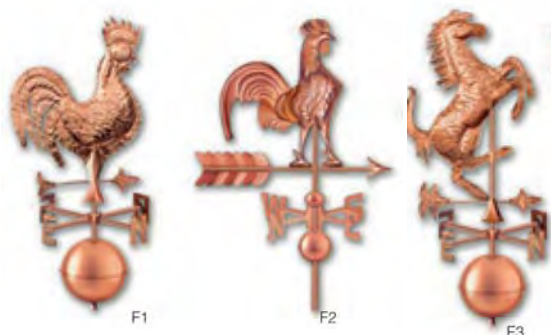

F1

F2

F3

code

F1	23601.X	pivoting cock with sphere
	2361.X	pivoting cock without sphere
	2362.X	pivoting cock with sphere and flag
	23602.X	pivoting cock with sphere C
F2	2359.X	Euro cock
	2364.X	Euro duck
	2369.X	Euro eagle
F4	23881	horse with cardinal points and sphere

AVAILABLE IN THE FOLLOWING MATERIALS
copper st.steel galvanised pre-painted alucopper

X

Sparrow guard/ scarer



code

2611.X scarer model

AVAILABLE IN THE FOLLOWING MATERIALS
copper st.steel galvanised pre-painted alucopper

X

Multi-spike pigeons scarer



code

26155 multi-spike copper and brass base
26152 multi-spike st.steel

AVAILABLE IN THE FOLLOWING MATERIALS
copper st.steel galvanised pre-painted alucopper

X X

Pigeons guard



code

2612.X wide model
2613.X narrow model

AVAILABLE IN THE FOLLOWING MATERIALS
copper st.steel galvanised pre-painted alucopper

X X

Pigeons guard-scarer



code

26053

AVAILABLE IN THE FOLLOWING MATERIALS
copper st.steel galvanised pre-painted alucopper polycarbonate

X

If you want to place an order, replace the "X" of the code with the number corresponding to the chosen material. X= 1 COPPER, 2 STAINLESS STEEL, 3 GALVANISED, 4 PRE-PAINTED, 15, RHEINZINK, 69 ALUCOPPER



Bent sparrow guard



codice

2605.X bent frontal

AVAILABLE IN THE FOLLOWING MATERIALS
 copper X st.steel X galvanised X pre-painted alucopper X

Sparrow guard

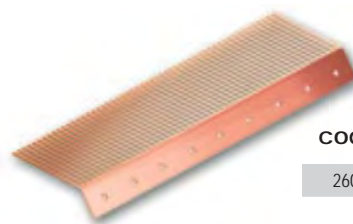

codice

2606.X comb-shaped

AVAILABLE IN THE FOLLOWING MATERIALS
 copper X st.steel X galvanised X pre-painted alucopper X

Expanded polyethylene sparrow guard (density 30 Kg/m³)



codice

26065 for Genus 160 negative SP 60

26066 for Genus 160 positive SP 60

26067 for Genus 900 SP 30

26068 for Genus 800 SP 30

Tarred sponge sparrow guard 25x10



code

26070 for Genus 900

26075 for Genus 1000 negative (=small part) (pitch 250/360 thk 25 h 10)

26076 for Genus 1000 negative (=big part)(pitch 250/360 thk 25 h 10)

26080 for Genus 2000

Tarred sponge seal 25x10



code

26082

Bored sheet plate (copper height mm)



code

6606060200 bored steel TDM 06 SV 200

6601050200 copper height 200 mm

6601050250 copper height 250 mm

6601050330 copper height 330 mm

66151 copper height 1000 mm

6606060250 bored steel TDM 06 SV 250

66159 rheinz. prep. height 1000 mm

99500 rheinz. prep. height 1000 mm

6606060300 prepainted height 300 mm TDM

6606030330 prepainted height 330 mm TDM

66503 st. steel height 330 mm

66150 aluminium height 1000x07 mm

66502 bored st. steel 0,5 height 200 mm

66512 bored st. steel 0,5 height 250 mm

66503 bored st. steel 0,5 height 330 mm

code

6607060200 prepainted bg height 200 mm

6607060250 prepainted bg height 250 mm

6607060330 prepainted bg height 330 mm

6607060400 prepainted bg height 400 mm

6607061000 prepainted bg height 1000 mm

6621080200 alucopper height 200 mm

6621080250 alucopper height 250 mm

6621080330 alucopper height 330 mm

Straight net



code

2609.X small net

26095 big net*

* only copper version available

AVAILABLE IN THE FOLLOWING MATERIALS
 copper X st.steel X galvanised X pre-painted alucopper X

Curved tile holder and thread

Curved tile-holder



code

2502.X	old curved tile - new curved tile
25034	fix curved tile 9x2.5 st. cop

AVAILABLE IN THE FOLLOWING MATERIALS

copper st.steel galvanised pre-painted alucopper

X X X

Curved tile-stopper first row



code

2512.X	old curved tile
25144.X	c. tile-stopper 20x2,5 st. cop

AVAILABLE IN THE FOLLOWING MATERIALS

copper st.steel galvanised pre-painted alucopper

X X X

Curved tile-holder first row Piemonte type



code

size cm

2505.X	30 cm
2506.X	35 cm
2507.X	40 cm

AVAILABLE IN THE FOLLOWING MATERIALS

copper st.steel galvanised pre-painted alucopper

X X X

Wire



code

size

5722.X	2 mm
--------	------

AVAILABLE IN THE FOLLOWING MATERIALS

copper st.steel galvanised pre-painted alucopper

X X X X

Snow guards

Standing seam snow guard for tiles

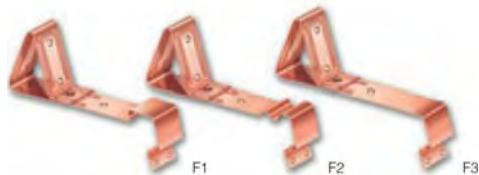

code

F1	2422.X	Marseillaise
F2	2422.X	Portuguese
F3	2422.X	for flat / cement tile

AVAILABLE IN THE FOLLOWING MATERIALS

copper st.steel galvanised pre-painted alucopper

X X X

Standing seam snow guard for curved tile



F1 code

	2401.X	for Greek narrow curved tile
F1	2431.X	for short curved tile
F2	2432.X	for medium curved tile

AVAILABLE IN THE FOLLOWING MATERIALS

copper st.steel galvanised pre-painted alucopper

X X X

Snow guard Malenco type



code

24004

AVAILABLE IN THE FOLLOWING MATERIALS

copper st.steel galvanised pre-painted alucopper

X

Snow guard for corrugated sheets



code

24123.X

AVAILABLE IN THE FOLLOWING MATERIALS

copper st.steel galvanised pre-painted alucopper

X X

If you want to place an order, replace the "X" of the code with the number corresponding to the chosen material. X= 1 COPPER, 2 STAINLESS STEEL, 3 GALVANISED, 4 PRE-PAINTED, 15, RHEINZINK, 69 ALUCOPPER

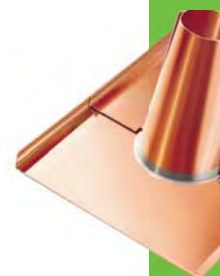

Snow guard for double seaming



code

99250	aluminium double pipe
99251	copper double pipe
99260	3/4" and 1" iron snow guards in aluminium SINGLE
99262	3/4" and 1" iron snow guards in cooper SINGLE PIPE
99263	3/4" and 1" trapeze-shaped iron snow guards in aluminium SINGLE PIPE

Press-folded snow guard



AVAILABLE IN ALL TYPES OF METAL. MEASURES AND LENGHTS ON REQUEST

Adjustable gutters

Adjustable square gutter

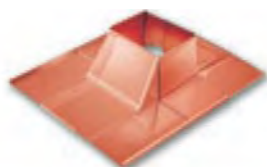

code	size
1178.X	I measure - adjustable 170x170 300x300 mm
1179.X	II measure - adjustable 300x300 500x500 mm
1180.X	III measure - adjustable 500x500 800x800 mm

AVAILABLE IN THE FOLLOWING MATERIALS
 copper st.steel galvanised pre-painted alucopper
 X X X X

Adjustable square gutter for curved til



code	size
1186.X	I measure - adjustable 170x170 300x300 mm
1187.X	II measure - adjustable 300x300 500x500 mm
1188.X	III measure - adjustable 500x500 800x800 mm

AVAILABLE IN THE FOLLOWING MATERIALS
 copper st.steel galvanised pre-painted alucopper
 X X X X

Lead gutter

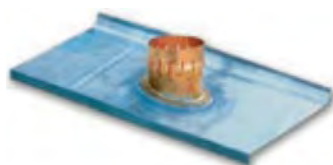

code	section Ø mm
11911	80
11921	100
11931	120
11941	140

AVAILABLE IN THE FOLLOWING MATERIALS
 copper st.steel galvanised pre-painted alucopper lead
 X

Chimneys (h.40 cm)



code	section Ø mm
23921	chimney with flaps diam. 80
23931	cchimney with flaps diam. 100
23941	chimney with flaps diam. 120
23971	chimney with flaps diam. 140
23951	chimney with flaps diam. 160
2700.X	chimney with net diam. 80
2701.X	chimney with net diam. 100
2702.X	chimney with net diam. 120
2703.X	chimney with net diam. 140
27041	chimney with net diam. 160

AVAILABLE IN THE FOLLOWING MATERIALS
 copper st.steel galvanised pre-painted alucopper
 X X X

Adjustable round gutter



code	type
1090.X	type medium
1092.X	type big

AVAILABLE IN THE FOLLOWING MATERIALS
 copper st.steel galvanised pre-painted alucopper
 X X X

Gutter for antennas

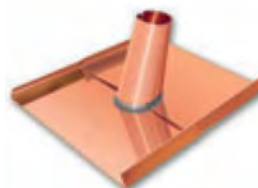

code
1091.X

AVAILABLE IN THE FOLLOWING MATERIALS
 copper st.steel galvanised pre-painted alucopper
 X X X

Chinese funnel



code	section Ø mm	
2373.X	80	
2374.X	90	
2375.X	100	
2376.X	110	
2377.X	120	
2378.X	130	
2379.X	140	
2380.X	150	
2381.X	160	
2382.X	170	
2383.X	180	
2385.X	200	
2386.X	220	
23866	250	copper
23867	250	st.steel
23868	260	copper
23870	270	copper
2387.X	280	
23876	300	copper
23877	300	st.steel

AVAILABLE IN THE FOLLOWING MATERIALS
 copper st.steel galvanised pre-painted alucopper
 X X X

Chinese funnel with coupling connection (h. 7 cm)



code	section Ø mm	
23733.X	80	
23755.X	100	
23777.X	120	
23799.X	140	
23922.X	80	copper w/net
23933.X	100	copper w/net
23944.X	120	copper w/net
23977.X	140	copper w/net

AVAILABLE IN THE FOLLOWING MATERIALS
 copper st.steel galvanised pre-painted alucopper
 X X X

Wind aspirators Ø 100-300 mm square

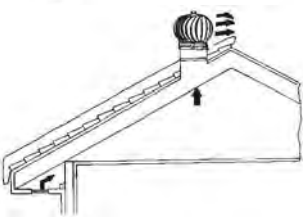
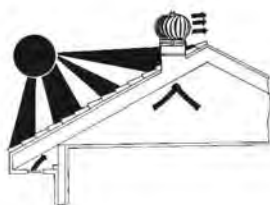

code	section Ø mm
0746.X	100
0747.X	120
0748.X	130
0749.X	140
0750.X	160
0751.X	180
0752.X	220
0753.X	250
0754.X	300
0760.X	220x220

IT REDUCES THE CEILING TEMPERATURE AND ENERGY COSTS IN AIR-CONDITIONED AREAS. IT ELIMINATED CONDENSATION

AVAILABLE IN THE FOLLOWING MATERIALS
 copper st.steel galvanised pre-painted alucopper
 X X

Copper chimneys kit + lead sheets

code	section Ø mm
236501	80
23651.X	100
23652.X	120
23653.X	140
23654.X	160

DISPONIBILE NEI SEGUENTI MATERIALI
 rame inox zincato preverniciato alucopper alluminio
 X X X

Almond aluminium



code	size mm
56250	2x1000x2000

AVAILABLE IN THE FOLLOWING MATERIALS
 copper st.steel galvanised pre-painted alucopper aluminium
 X

If you want to place an order, replace the "X" of the code with the number corresponding to the chosen material. X= 1 COPPER, 2 STAINLESS STEEL, 3 GALVANISED, 4 PRE-PAINTED, 15, RHEINZINK, 69 ALUCOPPER

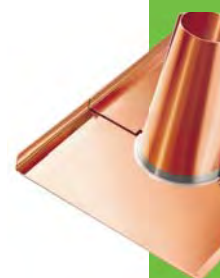

Expansion joints

Technical information



Unimetal expansion joints are aimed at compensating expansion. They are used for the application of gutters, drainpipes for shed coverings, recessed rectangular gutters, parapets, walls coverings, flat roofs framing, walls cladding.

Expansion joints consist of two metal stripes on which an elastic intermediate element is vulcanised. Such rubber element represents the actual expansion part.

Expansion joints can be provided in all the materials available on the market:

- titanium zinc
- copper
- aluminium
- stainless steel
- pre-coated titanium zinc
- quartz zinc, anthracite zinc Uginox
- Uginox AME
- Uginox FTE
- Tecu Green
- coating Tecu Oxyd
- Hot-dipped Tecu zinc
- Galvanised steel plate

code	size mm	material
58206	390	aluminium
58199	260	st. steel
58203	310	pre-coated
58196	260	copper
58201	310	copper

Special parts

Articulated pipe elbow



code	section Ø mm
	100
	120
	130
	140
	150
	160
	180
	200

Tee, Conn. pipe, Reduction

UNIMETAL CAN PROVIDE SPECIAL PARTS ON REQUEST WITH ST. STEEL, COPPER AND PRE-PAINTED FINISHINGS

AVAILABLE IN THE FOLLOWING MATERIALS				
copper	st.steel	galvanised	pre-painted	alucopper
X	X			X

If you want to place an order, replace the "X" of the code with the number corresponding to the chosen material. X= 1 COPPER, 2 STAINLESS STEEL, 3 GALVANISED, 4 PRE-PAINTED, 15, RHEINZINK, 69 ALUCOPPER



Pipes and lead accessories

W.C. supply tube 60x90/60x100 mm



code

57130

AVAILABLE IN THE FOLLOWING MATERIALS
copper st.steel galvanised pre-painted alucopper lead
X

Floor syphon



code

section Ø mm

57201

100/3

57202

120/4

AVAILABLE IN THE FOLLOWING MATERIALS
copper st.steel galvanised pre-painted alucopper lead
X

Mexican



code

section Ø mm

08020

80

08040

100

08060

120

AVAILABLE IN THE FOLLOWING MATERIALS
copper st.steel galvanised pre-painted alucopper lead
X

Consumables

Silicon Torggler



code

colour

57471

R6005

57469

dark brown

57468

grey

57470

copper

57472

brick red

57474

neutral

57477

sand grey

Sika roll sealtite



code

height cm

57391

10

57393

15

57398

30

Tin



code

rod

57300

50%

57320

40%

57340

35%

virgin tin on request

Degussa welding



codice

descrizione

F1

57275

Soldaflex 7000

F2

57250

Degufit 3000 prof.

F2

57260

Degussa 94 bars copper 2x2x500

F4

57290

Dasifix 3 Tin Alloy

F5

57280

Degussa abrasive sponges

57255

Degussa cartridge refill x Degufit 250 gr.

57274

Degussa RS/M deoxidiser liquid

F6

57285

Degussa Carpet 500x330 mm



Ammonia salt tablet, box



code	description
57560	tablet
65965	box

Acid for welding



code	description
57540	st. steel weld.
57550	Sald fair L.1
57539	Saldor S 53 Kg. 1
57538	Saldor S 53 Kg. 1/2

Patches for welding 2-piece packs



code	description
57770	2-piece pack

Stearin



code	description
57620	stearin

Torggler polyurethane foam 750 ml



code	description
57652	pack 750 ml.

Cemblock base



code	description
57631	ready - pack Kg. 25
57632	concentrated - pack Kg. 25

Spray-paint



code	description
57761	bg
57762	blu r5010
57763	silver r9006
57764	green r6005
57765	Sienna red
57766	grey r7015
57767	copper
57760	dark brown
57768	green r. gori
57769	anthracite grey r7016

Cemblock film



code	description
57635	type A
57636	type B
57637	type C

Materials for coverings

Wooden slats, L=4 m



code	description
76010	4x4 mt.
76020	5x4 mt.
76030	6x4 mt.
76040	6x8 mt.

Pre-perforated sheets

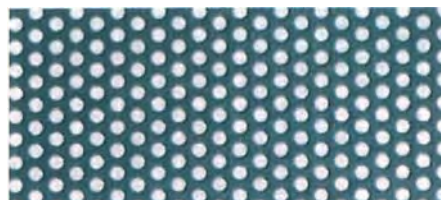

In our storehouse, we have a wide range of very original perforation possibilities, from round ones to square ones, with straight or shifted pitches, but also hole perforation and decorative ones. The equipment we work with ensure absolute precision of the perforated end-product. We use the most modern perforation presses to process polished and galvanised steel, high-quality stainless steel, aluminium, copper and titanium zinc.



RHEINZINK



Rheinzink accessories

Accessories

Rheinzink T.S. covered gutter-hangers



code	description
99219	round-25/25/6-titanium zinc cov.
	round-25/25/6-titanium zinc cov.
99218	round-28/25/6-titanium zinc cov.
99222	round-33/25/6-titanium zinc cov.
	round-40/25/6-titanium zinc cov.

Solid Rheinzink collars with screw



code	description
99315	Ø 60 - polished
99305	Ø 80 - polished
99306	Ø 100/100 - polished
99310	Ø 120/100 - polished
99402	screw for collar

Rheinzink wheels



code	description
99184	Ø 80/92
99181	Ø 100/110
	Ø 120/142
99182	Ø 100/150
99183	Ø 80/150

Expansion joint 3 mt. -linear pieces

code	description
58203	310



Sheath for Rheinzink covering

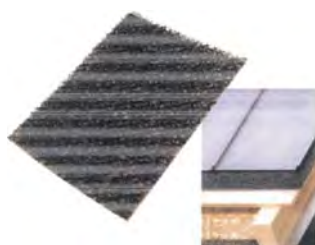

code	description
58348	air-z filam.trid.rhe mat

Anti-condensation felt



code	description
76400	surface 1,2 mt.
76410	surface 1 mt.

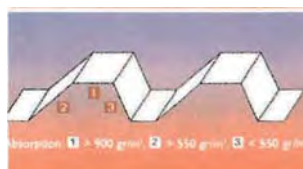
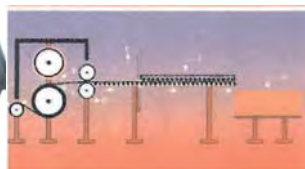

Rheinzink nozzles "Pipe coupling"



code	description
99100	round- Ø 28/80 - pre-coated
99106	round- Ø 33/80 - pre-coated
99101	round- Ø 33/100 - pre-coated
	round- Ø 40/120 - pre-coated

Rheinzink welded curves



code	description
99160	Ø 800/72° - pre-coated
99163	Ø 100/72° - pre-coated
99164	Ø 120/72° - pre-coated
99159	Ø 60/72° - pre-coated
99172	Ø 80/40° - pre-coated
99173	Ø 100/40° - pre-coated
99165	Ø 100/85° - pre-coated
99172	Ø 120/40° - pre-coated

Rheinzink perforated plate 4/5 o 5/7 mm (sheet)

code	description
99500	round hole 5/7 1x2x1,00x1

Air grip bi-adhesive tape roll 40mm x 25mt

code	description
58319	air grip bi-adhesive tape 40mmx25mt.

Galvanised nails



code	description
99400	rheinzink 2,5 mm

Lotwasser 204S Rheinzink acid



code	description
99200	

Sheath for Rheinzink cov.

code	description
58349	vapozinc mat +membrane



PVC

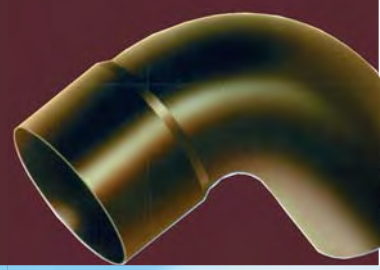

PVC downspouts
PVC accessories

PVC downspouts

Downspout



code	description
30210	Ø 63 - length mt. 3
30220	Ø 82 - length mt. 3
30260	Ø 100 - length mt. 3
30270	Ø 125 - length mt. 3

Pipe elbow



code	description
31070	Ø 63 - angle 45°
31080	Ø 63 - angle 67°
31090	Ø 63 - angle 87°
32070	Ø 82 - angle 45°
32080	Ø 82 - angle 67°
32090	Ø 82 - angle 87°
32170	Ø 100 - angle 45°
32180	Ø 100 - angle 67°
32190	Ø 100 - angle 87°
32210	Ø 125 - angle 45°
32212	Ø 125 - angle 67°
32214	Ø 125 - angle 87°

PVC accessories

Conn. pipe



code	description
32221	8x8 - angle 87°
32222	10x10 - angle 67°
32217	Ø 82 - angle 45°
32218	Ø 82 - angle 67°
32219	Ø 82 - angle 87°
32227	Ø 100 - angle 45°
32228	Ø 100 - angle 67°
32229	Ø 100 - angle 87°
32237	Ø 125 - angle 45°
32238	Ø 125 - angle 67°
32239	Ø 125 - angle 87°

Reducers



code	description
32270	Ø 82/63
32271	Ø 100/82
32272	Ø 120/100

Additional part



code	description
32280	Ø 63/82
32282	Ø 82/100
32284	Ø 100/120

Straight - shockproof - black terminal



code	description
34340	Ø 80 - length mt. 2
34440	Ø 100 - length mt. 2

Round pipe elbow - shockproof - black terminal



code	description
34710	Ø 80 - length mt. 2
34730	Ø 100 - length mt. 2

Square pipe elbow - shockproof - black terminal



code	description
34790	100x100 - length mt. 2

PVC Mexican

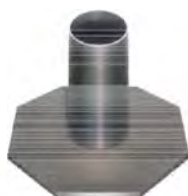

code	description
08120	Ø 80
08140	Ø 100
08160	Ø 125
	Ø 140
	Ø 160

Leaves grid



code
08250

Round grey well



code	description
08260	Ø 80



FIXINGS AND ACCESSORIES



Nails
Dowels
Screws
Parts without seal
Parts with baz seal
Parts with A 16 seal for coverings
Rivets

Nails

Bolt with nut mm (ØxL)



code	description
41538	in T.E. st. steel 6x20
41539	in T.E. copper 6x30
41534	in T.E. st. steel. 6x30
41535	in T.E. galvanised 6x30
41541	in T.B.L. copper 6x20
41542	in T.B.L. st. steel 6x20

Broad-headed nail mm (ØxL)



code	description
4240.X	3x30 mm
4242.X	4-3,5x40 mm
4244.X	4-3,5x50 mm

Broad-headed iron nail mm (ØxL)



code	description
44320	18x40 mm - pack 5 Kg
44321	18x40 mm - pack 2,5 Kg
44330	18x50 mm - pack 5 Kg
44331	18x50 mm - pack 2,5 Kg

Dowels

Quick dowel with broad-headed copper screw mm (ØxL)



code	description
41336	6x40 mm

Quick dowel nail with screw mm (ØxL)



code	description
41300	quick w/iron screw 6x40/6x50
41350	quick w/copper screw 6x40

Quick dowel nail with stud mm (ØxL)



code	description
41330	quick w/screw+copper stud 6x40
41332	quick w/screw+st. steel stud 6x40
41334	quick w/screw+pre-coated stud 6x40
41341	quick w/screw+copper stud 6x60 mm
41342	quick w/screw+st. steel stud 6x60 mm
413346	quick w/screw+stud 6x60 mm BG

Dowel nail mm (ØxL)



code	description
41997	80x80 mm
41998	80x100 mm
41999	80x120 mm
42001	100x135 mm
42002	100x160 mm

Nylon dowel Ø 8 mm



code	description
41570	Ø 8 mm + nail
22900	galvanised pivot with ring 8x180

Screws

Screw with washer mm L



AVAILABLE IN THE FOLLOWING MATERIALS	
copper	st. steel
X	X

code	description	code	description
4102.X	35 mm	4107.X	100 mm
4104.X	45 mm	4109.X	120 mm
4106.X	70 mm	410995	35 TDM st. steel
4108.X	80 mm	411005	45 TDM st. steel
4105.X	90 mm	41100	copper-plated st. steel 45
		41101	copper-plated st. steel 25



Parts without seal

Screw for wood mm (ØxL)



The following measures are also available on request:
6x25, 6x30, 6x35, 6x40, 6x45, 6x150, 6x160, 6x170, 6x180. 6x160, 6x170.

code	description
41123	6X40 mm
41143	6X60 mm
41163	6X70 mm
41183	6X80 mm
41203	6X90 mm
41223	6x100 mm
41243	6X110 mm
41263	6x120 mm
41273	6X130 mm
41283	6X140 mm

Nylon-headed screw for wood mm (ØxL)



code	description
41170	6,5X75 mm
41180	6,5X80 mm
41200	6,5X90 mm
41183	6X80 mm
41240	6,5X130 mm

Galvanised self-tapping screw for iron mm (ØxL)



The following measures are also available on request:
6x22, 6x25, 6x32, 6x38.

code	description
41700	6X35, 6X50 mm - 25
41710	6X60 mm
41720	6X70 mm
41730	6X80 mm
41740	6X90 mm
41750	6x100 mm
41770	6X120 mm
41780	6x130 mm
41792	6X140 mm
41796	6X160 mm

Galvanised self-tapping screw for iron mm (ØxL)



code	description
41410	6X25, 6X35, 6X50 mm
41430	6X60 mm
41470	6X70 mm
41490	6X80 mm
41500	6X90 mm
41510	6X100 / 120 / 130 mm
41530	6X150 mm

Galvanised screw for wood mm (ØxL)



code	description
42910	brunished flared head 6X70 mm
42920	brunished flared head 6X90 mm

Screw for cement mm (ØxL)



code	description
41118	6X80 mm T. Glinrica
41113	7,5X45 mm T. Mush
41114	7,5X50 mm T. Mush
41115	7,5X60 mm T. Mush

Parts with baz seal

Galvanised screw for wood mm (ØxL)



code	description
43434	6X70 mm
428410	6X70 mm self-perforating
43435	6X80 mm
428510	6X80 mm self-perforating
43470	6X120 mm
429010	6x120 mm self-perforating
43480	6X150 mm
43490	6X170 mm
428310	6,3X60 mm self-perforating
428710	6,3X100 mm self-perforating
429020	6,3X130 mm self-perforating
429040	6,3X140 mm self-perforating
429050	6,3X150 mm self-perforating
429060	6,3X160 mm self-perforating
429070	6,3X180 mm self-perforating

St. steel screw for wood mm (ØxL)



The following measures are also available on request:
6x40, 6x50, 6x60, 6x130, 6x140, 6x150, 6x160, 6x170.

code	description
41592	6X70 mm
41602	6X80 mm
41612	6X90 mm
41632	6X100 / 110 mm
41652	6X120 / 130 mm

St. steel self-tapping screw for wood mm (ØxL)



The following measures are also available on request:
6x40, 6x50, 6x60, 6x130, 6x140, 6x150, 6x160, 6x170.

code	description
41662	6X60 / 70 mm
41666	6X80 mm
41667	6X100 mm

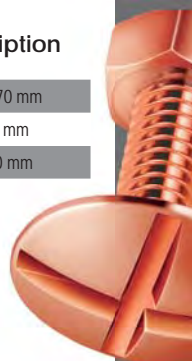

Parts with A16 seal

Galvanised screw for wood

mm (ØxL)



The following measures are also available on request:

6x20, 6x30, 6x40, 6x45, 6x160, 6x170, 6x180.

code	description
411233	6X40 mm
411433	6X60 mm
411633	6X70 mm
412233	6X100 mm
412433	6X110 mm
412633	6X120 mm
412733	6X130 mm
412833	6X140 mm
412933	6X150 mm
411133	4,8X35 mm
42830	6,3X60 mm self-perforating
42840	6,3X70 mm self-perforating
42850	6,3X80 mm self-perforating
42860	6,3X110 mm self-perforating
42880	6,3X120 mm self-perforating
42890	6,3X130 mm self-perforating
42900	6,3X140 mm self-perforating
42930	6,3X150 mm self-perforating

St. steel screw for wood

w/seal A16



code	description
43540	4,9X35 mm
43560	5,6X35 mm
43580	6X40 mm
43590	6X60 mm
43600	6X70 mm
43650	6X80 mm
43670	6X115 mm
43680	6X120 mm
43690	6X130 mm

Galvanised self-tapping screw for iron w / A 16 seal



code	description
414103	6X25 8 6X35 / 6X50 mm
414303	6X60 mm
414503	6X65 mm
414703	6X70 mm
414903	6X80 mm
415003	6X90 mm
415103	6X100 / 6X120 / 6X130 mm
415303	6X150 mm

Galvanised self-tapping screw for iron seal

mm (ØxL)



code	description
42505	6X25 mm
42507	6X32 mm
42509	6X38 mm
42510	6X50 mm
42520	6X60 mm
42530	6X70 mm
42540	6X80 mm
42550	6X90 mm
42560	6X100 mm
42570	6X110 mm
42580	6X120 mm
42590	6X130 mm

St. steel self-tapping screw for iron

mm (ØxL)



code	description
42610	5,5X25 mm
42630	5,5X50 mm
42640	5,5X60 mm
42650	5,5X80 mm
42680	5,5X90 mm
42700	5,5X110 mm
42710	5,5X130 mm

Accessories for coverings

Washer with vulcanised EPDM A16

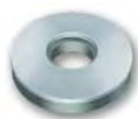

code
41674

St. steel screw for wood w/seal A16



code	description
41676	5,5X25 mm
41679	5,5X25 mm

Adjustable support stand



type	code	h. min. mm	h. max mm	type	code	h. min. mm	hmax mm	type	code	h. min. mm	hmax mm
1	25950	12	190	8	25956	500	580	15		860	940
2	25951	145	225	9	25957	550	630	16		890	970
3	25959	165	245	10		610	690	17	25958	1000	1080
4	25952	200	280	11	25960	670	750	18	25963	435	515
5	25953	250	330	12	25961	750	830				
6	25954	330	410	13	25962	805	885				
7	25955	400	480	14		840	920				



Cap for corrugated sheets no/seal 2,5 cm

The following measures
are also available on
request: 3,5 - 4,0 mm

Seal for cap

AVAILABLE IN
THE FOLLOWING
MATERIALS

ruberoïd

x

code description

44200 in PVC rubber

Riblok - galvanised bracket



code

41693

Riblok - galvanised bracket

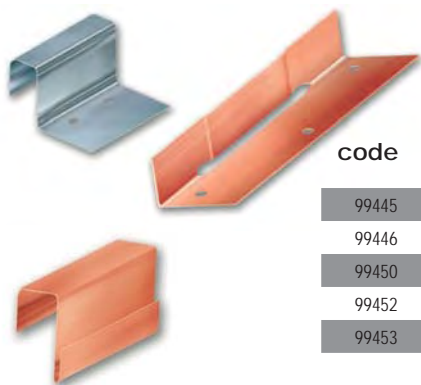

code description

99445 fix / copper

99446 fix / st.s. 25 mm

99450 sliding / copper

99452 sliding / st.s.25 mm

99453 sliding / st.s.32 mm

Cap for corrugated sheets with seal



code description

44080 2,5-3,5 cm natural aluminium

44081 2,5-3,5 cm copper

44084 2,5-3,5 cm pre-p. white-grey sheet

440845 2,5-3,5 cm dark brown pre-p. sheet

440847 2,5-3,5 cm pre-p. Sienna red sheet

440848 2,5-3,5 cm cm pre-p. sheet RAL 6005

44085 2,5-3,5 cm cm pre-p. white aluminium

440855 2,5-3,5 cm cm pre-p. d. brown aluminium

440857 2,5-3,5 cm cm pre-p. Sienna red aluminium

440858 2,5-3,5 cm cm pre-p. aluminium RAL 6005

44087 2,5-3,5 cm cm pre-p. aluminium various colours

Silhouette Profile

code description

77070 Silhouette

77069 Silhouette for TT curved tile

Rivets

Rivet with iron shaft mm (ØxL)

The following measures
are also available on
request 3,4X12 mm



code description

4002.X 3,2X7 mm

4008.X 3,2X9 mm

4009.X 3,2X11 mm

4004.X 3,4X7 mm

4005.X 3,4X9 mm

4016.X 3,9X7 mm

4018.X 3,9X9 mm

4019.X 3,9x12 mm

4023.X 3,9X16 mm

4038.X 4,8X9 / 4,8X10 mm

4040.X 4,8X14 mm

4041.X 4,8X20 mm

Rivet with brass / bronze shaft mm (ØxL)



code description

40061 brass shaft 3,2X7 mm

40111 brass shaft 3,8X9 mm

40071 bronze shaft 3,2X7 mm

40151 bronze shaft 3,9X9 mm



Flower rivet mm (ØxL)



code	descrizione
40420	4,8X30 mm / aluminium
40440	5X40 mm / aluminium
40480	4,8X60 mm / aluminium
40421	5X30 mm / copper
40461	5X40 mm / copper

Watertight blind rivet mm (ØxL)



code	descrizione
40026	3,2X6,5 mm / copper
40031	3,2X8 mm
40171	3,9X10 mm
40201	3,9X12,6 mm
40410	4X9,5 mm / aluminium
40409	4X11 mm / aluminium
40292	4X8 mm / st.steel
40272	4X9,5 mm / st.steel
40282	4X12 mm / st.steel

Extra short drill bit



code	description
62120	Ø 3,5 mm
62140	Ø 4,0 mm

Double drill bit



code	description
62160	Ø 3,5 mm
62170	Ø 4,0 mm

Laser bit (cobalt-extra short)



code	description
62420	Ø 3,5 mm
62430	Ø 4,0 mm

Widiman SDS plus bit mm (ØxL)



code	descri
62340	6X160 mm
62350	8X160 mm
62370	9X160 mm
62360	10X160 mm
62380	12X210 / 150 mm
62400	14X160 mm
62410	15X160 mm
62440	16X310 / 250 mm
62450	18X200 mm
62460	20X200 mm



EQUIPMENT



Equipment
Machineries for metal systems
Electric tools

You might also like our
catalogue **TOOLS**

You can download it from our website
www.idrocentro.com or you can send
an email to info@idrocentro.com



Equipment

Unimetal selects the best processing tools. This is why the tools we offer are practical when working with small sizes besides being extremely functional. They belong to a complex system that has already been tested by our Customers.

We offer: shears of several types, clamps, angular seamers, double seamers, benders, double paddles, riveters, swatches for welders, socketing machines, hammers and mallets, hacksaws, silicon guns, belts and tool-holders and other protective equipment.

Tools for metal systems and coverings



Machineries for metal systems

UK 100 manual segment bender

Universal segment manual bender, perfect for creating, whether on building sites or in workshops, cases, caps, façade coverings. User-friendly and accurate.

Thanks to the quick fixing system, its sliding and modular segments, with variable length, can be inserted using only one hand. The sheet is fixed through a lever or pedal.

The upper jaw opens up to 100 mm. Bending scale on both sides with adjustable stop for equal bending angles. Provided with its toolbox.

Technical data

processing length	1000 mm
performance	from 1 mm up to 2 mm



Manual bender with shears 2 mt. RVE 200

Manual bender complete with shears. Light and easy to carry around. The upper part is open. Rotating blades. Welded steel structure for better results.



code description

65257	manual bender w/shears 2 mt. RVE 200
-------	--------------------------------------

Mini profiling machine for roofs

Profiling machine for standing seam metal roof.



code description

65257	mini profiling machine for roofs
65113	mini profiling machine for roofs

LBX manual bender

The best-selling and the most widespread manual bender, both on building sites and in workshops. Features: perfect to be used on building sites. Provided with 20° upper blade with 1.5 mm radius with blades having different radiuses. Scale indicating both left and right bending angle, stand and wheels (*only LBX 200-250). The inclination of the upper part corresponds to 45° and allows bending up to 135° or 160° in case of bends up to 20 mm. Provided with springs in order to facilitate lifting the bending flange. Manual cutter with rolls. Optional.

Technical data

Processing thickness: galvanised sheet 0.63 mm, aluminium 1 mm, copper 0.80 mm.

Manual cutter. Optional.

Upper blade provided with 20° radius = 1.5mm. It can be replaced with blades having different radiuses.

Scale indicating both left and right bending angle. Upper inclination is 45°. It allows bending up to 135°.

code	65122	65125	
model	LBX 200	LBX 250	LBX 310
processing length mm	2040	2540	3100



RVX 200 manual bender

Light and handy. Open back.

Removable stand. Welded steel structure for better results. The machine is provided with 4 wheels with blocking system. Shears and sheet block to be ordered separately.

code description

65261	manual bender RVX200
65259	shears for bender RVX200



Manual edge bander

Manual edge bander.



code	description
65095	manual edge bander

Case with socketing machine

code	description
65011	
65094	

Electric tools

Nibbler RN 200-4 230V

Portable and handy nibbler, with rotating tool-holder shaft to change the cutting direction as desired. Max. cutting thickness: 1.6 mm, min. curvature radius: 50 mm. The tool-holder extension allows cutting, quickly and accurately, profiles and corrugated and trapezoidal sheets at a depth of 162 mm.



Shears S160 E 230V

Light and handy manual shears. Ideal to work on thin sheets, up to 1.6 mm thick. Pre-adjusted knife for all thicknesses. Ergonomic handle. The 4 edges knife can be easily replaced. Power 350 Watt, weight 1.9 Kg.



Special shears C160-0

Handy special shears to perform accurate and clean cuts, with no need of further finishings. Possibility to perform sheet processing also on curved sections. Easy and quick replacement of the knives.

No need to use service wrenches. Max. cutting thickness: 1.6 mm. Power 350 Watt, processing speed: 6/10 m / min.



Drill ASB 12-2-EUQ

Battery-powered impact drill, 12 Volt. Two electronic speeds: 0-340/0-1200 rounds per minute. Steel and cement hole diameter 13 mm and wood hole diameter 30 mm. Provided with metal case, battery charger and 2 batteries.



ASbe 642 keys

Electronic pulse wrench, adjustable up to 5 positions, for screws up to M 18. Power: 400 Watt, 220 V. Weight 3.1 Kg



COURSES FOR METAL SYSTEMS WORKERS

Unimetal periodically organises courses in order to learn Reinzink and Cooper processing methods

INFO
INVIARE MAIL

sandra@unimetal.net

You might also like our catalogue **TOOLS**

You can download it from our website www.idrocentro.com or you can send an email to info@idrocentro.com



HEAT AND SMOKE VENTS WINDOWS FOR ROOFS



Baggi-Lux products
Lighting and natural
light transport
Heat and smoke vents
Velux products
Instructions to choose a
window for roofs

Baggi-Lux products



We import sunlight, we export smoke and heat

Baggi-Lux is specialised in selling and installing energy efficient lighting systems with advanced technologies. From fibreglass skylights to smoke and heat vents. From light transporting devices to opening devices. A wide range of well-differentiated products in order to meet the market requests and in line with the norms in force. Customised production according to the client's request. Immediate application and scheduled maintenance procedures, post-sale, on heat and smoke vents.

Bases for skylights for all kinds of coverings except for standing seam ones. Fans for natural ventilation and opening systems for domes: manual, electric, hand-hole opening systems.

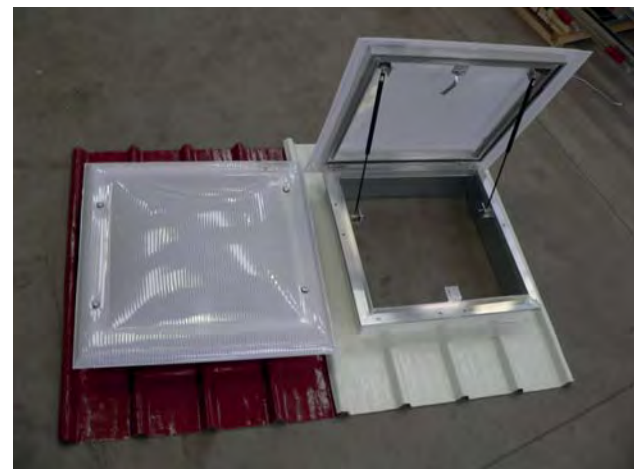
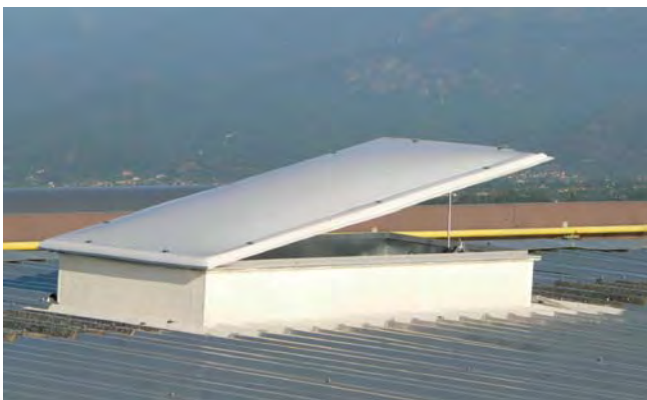

Solid and alveolar polycarbonate domes

SUNLIGHT-PC-PD

SUNLIGHT-PC-PD (UNI EN 1873:2014) dome, dual wall, in polycarbonate. Obtained through thermoforming of polycarbonate flat sheet (PC) (Type LIX® LEXAN®, Makrolon®), protected U.V. to prevent it from turning yellowish over time. Colour opal+transparent on request). Walls thickness 3-4+3 mm. Class B-s1-do (UNI EN 13501-1:2009). Sail-like shape, clear span cm x (size of the external support edge including the sheath cm +12 clear span, skylight external encumbrance cm +20 clear span).

Fixing is performed by means of a self-perforating screw provided with stainless steel washer with EPDM butz. Complete with EPDM airstop sealings, Class M1 F1(UNI EN 13501-1:2009) and application accessories. Compliant with UNI EN 1873:2006.

SUNLIGHT-ALVEOLARE16

SUNLIGHT-ALVEOLAR (UNI EN 1873:2014) dome, multiple wall, anti-condensation. Obtained through thermoforming of alveolar polycarbonate flat sheet (LEXAN®, Makrolon® type), reinforced, anti-hail. U.V. Protected so as to prevent it from turning yellowish over time. Diffuser opal colour. Thickness 16mm, weight 2.8 kg/mq, Class B B-s1-do (UNI EN 13501-1:2009). Sail-like shape, clear span cm x (size of the external support edge including the sheath cm +12 clear span, skylight external encumbrance cm +20 clear span). Fixing is performed by means of a self-perforating screw provided with stainless steel washer with EPDM butz. Complete with EPDM airstop sealings, Class M1 F1(UNI EN 13501-1:2009) and application accessories. Compliant with UNI EN 1873:2006.

Solid and alveolar polycarbonate modular skylights

Modular SUNLIGHT-PC (UNI EN 14963:2007). Continuous, modular skylight. In polycarbonate. Depressed-arch shape with ribs to keep it rigid. It consists of n°2 heads and of n° intermediate parts.



Monolithic glass fibre dome

ULTRALIGHT-PD

SHUTTERPROOF monolithic dome ULTRALIGHT-PD (UNI EN 1873:2014), double wall, anti-condensation, polyester resin with high transparency degree. Light stabilisation and reinforced with top-quality glass fibres. One layer of gel-coat prevents the glass fibres from surfacing due to weather conditions. Thickness 3-4+3 mm. Class E (UNI EN 13501-1:2009). Sail-like shape, clear span cm x (size of the external support edge including the sheath cm +12 clear span, skylight external encumbrance cm +20 clear span). Fixing is performed by means of a self-perforating screw provided with stainless steel washer with EPDM butz. Complete with EPDM airstop sealings. Class M1 F1(UNI EN 13501-1:2009) and application accessories. Compliant with UNI EN 1873:2006.



Large size also available, up to 5 mt x 5 mt.



Lighting and natural light transport



Solarpipe-Lux

ENERGY EFFICIENCY AND LIGHT TRANSPORT:

skylights evolution

Solarpipe-LUX® mainly consists of pipes that, thanks to their internal specular surface, transport light inside any building to reach the desired area.

Despite long distances, light never gets dispersed. To improve light collection, a channelling static system is placed under the dome (reflecting dish). During assembly, orientate it facing SOUTH.

Once having travelled along the pipe and after having reached the area to be lit (also with horizontal path), the ceiling light diffuses the light in the area: the ceiling light is available on request with several acrylic diffusers with optic effect.

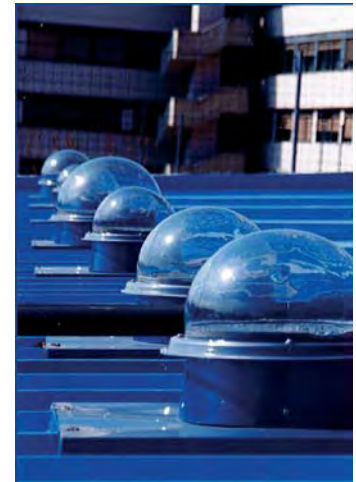
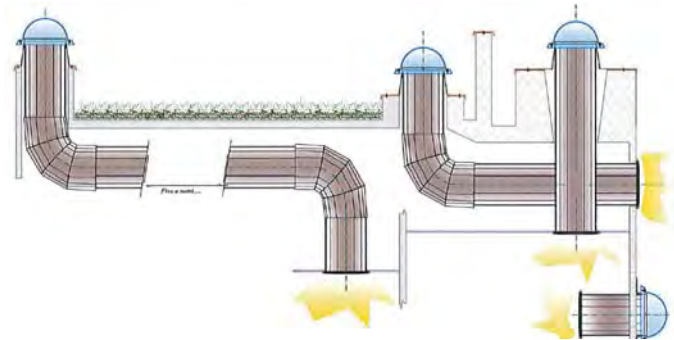

Powerpipe-Lux

Powerpipe-LUX® system is an innovative dome device provided with reflecting dish for movable light collection that ensures maximum light during the day. The pointing system, with orientation through GPS, placed on the skylight, constantly orientates the dish in the best direction in order to obtain the best light reflection inside every device. A solar panel, integrated in the system, turns the light into energy. This will then be transferred to the orientation device. The mirror inclination allows capturing sunlight also with medium/low inclination angles.

Communication among different devices is possible thanks to a mother cell, so that all the systems are perfectly in synch. It mainly consists of pipes that, thanks to their internal specular surface, transport light inside any building to reach the desired area. Despite long distances, light never gets dispersed. Unlike any other skylight currently on the market, this system literally chases sunlight in order to improve efficiency.



Heat and smoke vents



Vertical and horizontal ENFC

Design and production of conceived solutions. Placed on roofs, Baggi-Lux heat and smoke vents allow quickly dispersing smoke and decreasing temperatures in areas where a fire has developed, so as to make rescue operations possible.

HSNV Heat and Smoke Natural Vent "SunSmoke 2000V-EVO", made in compliance with norm (UNI EN 12101-2:2004), with Certification CE n° 0497/CPR/4454 in line with Directive 89/106/CEE Building Products, modified by Directive (CPD) 93/68/CEE, European Regulation (CPR) 305/2011/UE. It consists of:

- frame and counter-frame with anticorrosive aluminium alloy extruded profiles EN-AW 6060 T4-T5-T6 (UNI EN 12020-2:2008). Assembled by means of chamfer. Complete with special hinges, snap-in sealings and EPDM airstop seal, Class M1 F1 (UNI EN 13501-1:2009). Application accessories included;
- patented telescopic support structure of the opening system in press-bent steel plate, C.N.C., thk 2-3 mm, FE 360 D S235J2 (UNI EN 10025:2009), laser-worked and powdered enamelled RAL 2010;
- N° 1 DOUBLE EFFECT, TELESCOPIC cylinder with 4 stages: 1° boring mm 80-100, 2° boring mm 63, 3° boring mm 50, 4° boring mm 32 with decelerator, (it allows opening and closing through remote box);

- cylinder encumbrance cm 40 40 (ENFC 700-1000), cm 45 (ENFC 1001-1300), cm 57 (ENFC 1301-1600);
- high-pressure CO2 bottle gr 40 (ENFC 700-1000) - gr 80 (ENFC 1001-1300) - gr 150 (ENFC 1301-1600);
- SELECTOR thermal valve provided with thermosensitive element with calibration std. at 68°C (93°-141°-182° available on request). It can be started from afar by means of pyrotechnic or electromagnetic actuator provided separately. It is controlled by a control unit with manual activation (emergency button) or automatic (smoke detection system), or by bottles provided with manual valve;
- telescopic cylinder supply pipes - PTFE selector valve with thin wall. Covered by a double braid of stainless steel thread AISI 304;
- it can be manually opened from the outside in case of periodic maintenance operations or checks;
- block, by means of the selector valve, in maximum opening position in order to prevent it from accidentally closing in case of wind or fire;
- Classification: reliability Re300, opening under load SL900, low environmental temperature T (00), wind load WL1500, heat resistance B300.

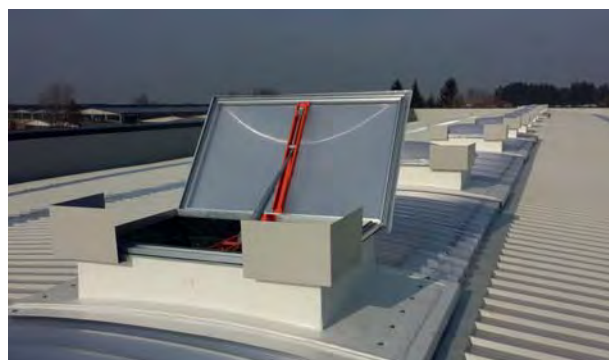
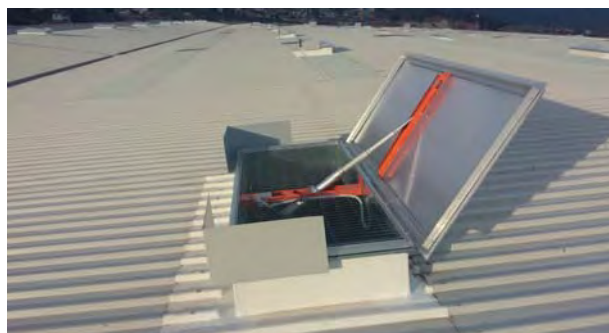
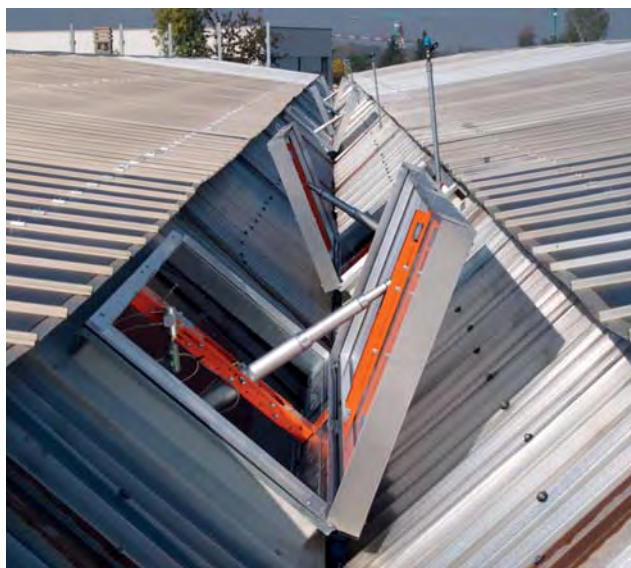

Velux products



Light is life

When a house is in harmony with the world, inside and outside, Velux is there. Windows for roofs, shutters, curtains, electric accessories and solar systems that are perfectly integrated in your spaces, turning them into welcoming attics.

Velux offers your life more light, air and quality. Day after day, night after night.



Windows for roofs



6 instructions to choose a window for roofs



1 - Choose the window model

For all roofs, whether flat or inclined, simple or complex, Velux has a solution to bring light and air into your house.



Before deciding on the best window model for your needs, bear in mind a few things: the impact of the opening of the roof in terms of natural light and solar efficiency; the possibility to install the window nearby in order to enjoy the view to the fullest.

VELUX windows are:

VERSATILE pivoting windows GGL/GGU

PANORAMIC window for roofs with double opening system: lift-up/pivoting GPL/GPU.

PROGRAMMABLE electric window for INTEGRA roofs GGL/GGU or window for solar INTEGRA roof GGL/GGU.

VELUX TRIPLE PROTECTION window for roofs that offers total protection GGL/GGU/GPU.

SOLAR TUNNEL for flat roof TCR or for inclined roof TWR/TLR.

WINDOW FOR FLAT ROOFS with dome CVP/CPF or with flat glass CVP/CFP.

2- Chose the finishing

VELUX windows can have different finishings, both internal and external, in order to meet all functional and aesthetic needs.

White internal finishing with wooden core

The windows for roofs with wooden core covered with white polyurethane don't require maintenance. Ideal for modern spaces. They are also perfect for wet rooms such as bathrooms and kitchens or in case of out-of-reach installation.

Wooden internal finishing

Wooden windows for roofs are treated with water-based transparent paint that protects the wood against dirt and humidity. Their classic design makes them ideal for either rustic or classic spaces.

External finishing

All VELUX windows are provided with a grey aluminium external coating. Other colours available on request.

The coating is also available in titanium zinc and copper to adapt to all coverings.



3 - Choose the size

There is the right size for all windows. The size must represent at least 25% of the room's walkable area. Simply follow this formula: $\text{room surface}/8 = \text{m}^2$ of the window.

Windows combination

VELUX windows can be combined in endless ways. They can be juxtaposed or overlapped. Ridge solutions to exploit zenith light are also available as well as structures to close terraces or balconies. A few examples of combinations.



4 - Choose the glass

VELUX windows glass ensure thermal insulation, energy efficiency, sound insulation, higher safety and privacy.

You can choose among several possibilities, also according to the climate zone.

Standard layered -70: for those who look for good performance, value for money, ideal to all climate zones.

Energy-60: combined with coverings and shutters, it guarantees the best energy balance all year long.

Performance -62: with a small difference in cost, it ensures excellent thermal and acoustic performance. Perfect against the noise of traffic or of the rain.

Energy Climate -66: for building with A and A+ class. The only one to be anti-hail and self-cleaning.



5 - Choose the installer

We always suggest asking VELUX professional installers to install your windows. Thanks to their experience, your windows will be properly installed, they will last over time and won't allow infiltration. Once installation has been completed, don't forget to ask your installer the CORRECT INSTALLATION CERTIFICATE. Velux installers use VELUX original products to install your windows.



6 - Choose coverings and shutters

Complete your VELUX window with either coverings or shutters: you will thus protect your attic against sunlight in the summer and cold in the winter. You will darken your room and decorate it. You can choose from a wide array of products, colours and functions. Pick the best one according to your needs. VELUX shutters and coverings are in line with the obligation to apply solar barriers outside glass surfaces in order to improve insulation on all new buildings and complete renovations.



Measurements list

Finestre per tetti (dimensioni esterne del telaio)

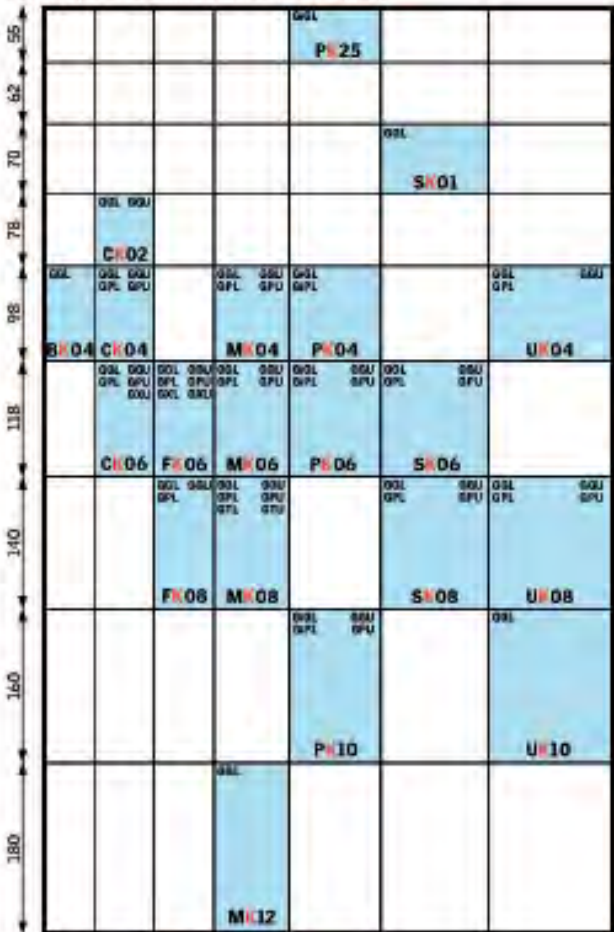

Elementi verticali

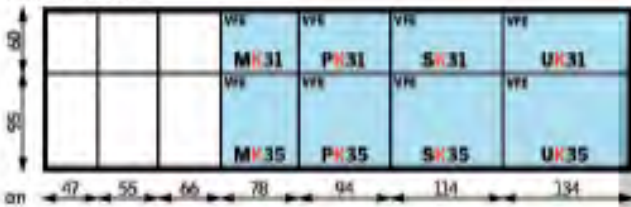

Raccordi per tetti piani con griglia

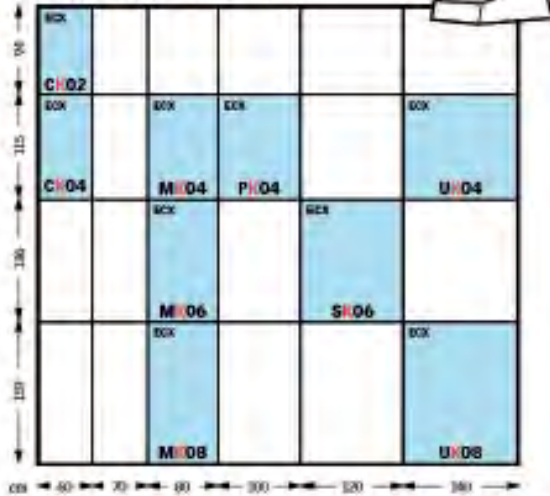

Finestra cupolino (dimensioni del foro nel solaio)



*Misura non disponibile per la finestra cupolino CUP con apertura manuale ad angolato.

Finestra balcone CABRIO

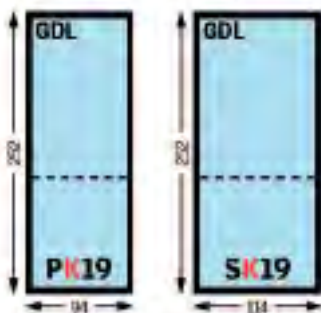

Superlucernario

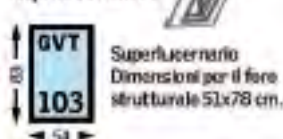



Instruction manual MATERIALS STORAGE



This manual shows how to properly store and install Unimetal products.
It is an integral part of the conditions of sale.

TO BE GIVEN TO THE INSTALLER AND TO BE CONSULTED BEFORE THE APPLICATION

Material maintenance storage and performance

1) WRAPPING AND PACKAGING

(reference norm UNI 10372) To ensure they last, metal components for coverings must not be damaged during storage, transport, handling and application operations. The materials are provided with simple standard packaging. It usually consists of small wooden bits or polystyrene. Different packaging modalities, to ensure greater protection, must be agreed upon while placing the order and will be included in the invoice.

2) FILM APPLICATION

If requested by the customer while placing the order, it is possible to apply a protective film (peeling-adhesive or on the surface) on the visible surface of the product in order to prevent scratches and scrapes.

Due to processing technical needs, such application can be performed by Unimetal, even where not expressly requested. In such case, the user cannot claim any form of reimbursement for its removal.



A) Storing precautions

During storing and handling procedures, some precautions must be adopted in order to guarantee the following:

- protection of the surface against scrapes, especially during handling procedures.
- protection of corners and edges against impacts and crashes;
- protection against water stagnation or humidity;
- protection of the elements holding the pack, or packs, against permanent deformation.

B) Quantity per packs

Profiled sheets and panels are usually packed in packs: the number of sheets or panels contained in each pack must not exceed the limits of lifting devices and transport means (usually 10/15 quintals). Smaller and lighter packs can be requested but this implies higher packaging costs.

3) FILM REMOVAL

The film must be removed from the metal systems, from the sheets and from the panels within 20 days from production, especially if the material was not protected, against high temperatures while being stored (see further instructions contained in this manual).

4) WITHDRAWAL OF READY-TO-USE MATERIAL

Once ready, the materials must be taken within maximum 15 days from the forwarding of the notice "ready goods". Should the goods NOT be taken within 15 days, Unimetal can invoice those goods in order to be paid. The goods that stay at Unimetal warehouses after 15 days from the forwarding of the notice are not covered by insurance in case of damages or deterioration. Unimetal shall not be held responsible. If the goods, due to further problems that don't depend on Unimetal, stay.



4) WITHDRAWAL OF READY-TO-USE MATERIAL

When stored in areas belonging to UNIMETAL for over a month, an additional storing cost shall be applied. Such cost amounts to 1% of the products worth for each week of permanence. Such cost shall be regularly invoiced. The goods must stay as little time as possible in UNIMETAL warehouses in order to prevent phenomena that might damage the products aesthetic: oxidation in case of humidity, difficulties in removing the film, colour changes. For the above-mentioned phenomena, UNIMETAL shall not be held responsible.

5) TRANSPORTATION

Transportation must be performed with suitable means and must respond to specific criteria:

- a) packs must be stacked interposing suitable spacers;
- b) the packs jolts must not exceed 1 mt. The packs must be placed on a flat surface. Wooden spacers, or expanded plastic material spacers, must be located under the packs. Their number and size must be appropriate and they must be perfectly vertically aligned.
- c) loading operations on vehicles that don't belong to UNIMETAL must be carried out on clear and clean platforms. Vehicles that are partially loaded with other materials or having inappropriate platforms cannot be accepted.
- d) the packs must be transversally fastened to the vehicle by means of belts placed with interaxis of up to 3 mt. Every pack shall be transversally fastened at least twice.
- e) the goods shall be placed on the vehicles following the carrier indications. He is the only person responsible for the load integrity. He shall make sure that the weight on the lower pack, as well as the pressure exerted by the fastening points, doesn't damage it. He shall also make sure that the belts don't deform the product:
- f) special loading conditions will be accepted only if requested in writing by the Purchaser, who takes on complete responsibility. Failure to comply with the above-mentioned rules exempts the manufacturer from responsibility.

6) INSTRUCTIONS FOR CHECKING THE GOODS DURING UNLOADING PROCEDURES

The Purchaser shall assess the products upon delivery. The Purchaser is responsible for damages caused to the products during transport even if the goods are sold on a delivered basis. Flaws and shortfalls must be reported upon delivery, under penalty of the warranty expiration. They must be reported on the transport document or within maximum 8 days. The products must not be installed.

In case of installation of faulty materials, the Warranty shall be void.

Costs related to stopping, storing or waiting shall be borne by the Purchaser, even if the goods are sold on a delivered basis and transportation is carried out with UNIMETAL's vehicles or with ones commissioned by the latter.



7) STORAGE

(see point 7.3 of norm UNI 10372)

Preliminary operations to be performed before applying the materials must be carried out with caution. We would like to underline here the importance of storing the materials correctly. Packs must be lifted from the ground at all times both in the warehouse and, especially, on the building site: they must be supported by wooden or expanded plastic materials parts. These shall be flat and longer than the width of the sheets. They shall be placed at adequate distance according to the product features. The resting surface shall be compatible with the packs shape: flat if the pack is flat: if the pack is curved, a suitable resting surface shall be created.

PAY ATTENTION to oxidation during storage: the packs shall not be placed in wet areas. They shall be inclined from the horizontal surface. They shall be repaired from rain and humidity in order to prevent water stagnation on the internal parts, which are less ventilated. Rain and condensation are particularly aggressive on metals and lead to oxidation (example: white rust for zinc).

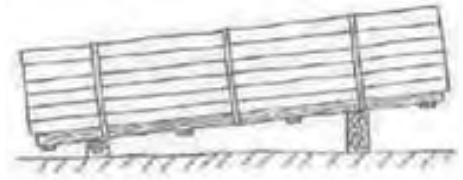

Avoid humidity stagnation between touching sheets.

Every product must be protected: from metal sheets, to panels, as well as metal materials.

UNIMETAL shall not be held responsible, and doesn't offer any form of guarantee, if the material shows oxidation stains etc. due to incorrect storage.

The packs shall be placed so as to facilitate water flow, especially when temporarily stored outside (see previous picture). Should storage not be carried out with application, cover the packs with protective covers.

Pay attention to possible electrochemical corrosion due to contacts among different metals during storage.

Packs shouldn't be stacked. If possible, due to their limited weight, always interpose wooden or expanded plastic materials spacers having a resting base as wide as possible. Their number must be sufficient and they must be placed near the supports of underlying packs (see picture).



The packs are best stored indoor, with good ventilation and without humidity and dusts. However, especially when stored at building sites, a stable resting surface must be envisaged in order to prevent water stagnation. The packs shall not be placed near working areas (example: cutting of metals, sanding, painting, welding, etc.) or in areas where vehicles transit or stopping might damage them (impacts, splashes, exhaust emissions, etc.) Up to three packs can be stacked, with overall height of about 2.6 metres. The number of the supports must be adequately increased.

8) MATERIALS COVERED BY FILM

Should the materials be covered with a protective film (peeling), this shall be completely removed during assembly and within and no later than 20 days from the preparation date of the materials, maximum 5 days from the application date of the materials.

Particular attention must be paid in case of storage outdoor. Without protection, in case of high temperatures or with no ventilation, the surfaces of the materials can be damaged.

The material must be opened or placed in a well-ventilated area. Galvanised, pre-painted or aluminium materials must be stored away from ferrous dust, chemical evaporation and soot due to diesel combustion. They lead to corrosion.



9) LIFTING AND HANDLING

Lifting must be performed with synthetic fibre belt (nylon). Width must be not

less than 10 cm. In this way, the load is distributed on the belt and doesn't lead to deformation (see picture). Spacers must be placed under and on the pack. They must consist of solid flat wooden or plastic parts in order to prevent the belts from directly coming into contact with the pack.

Such spacers must be at least 4 cm long. Their length must exceed the pack width. Their width must not be lower than the belt width.

Lower spacers must be wide enough to prevent the weight of the pack from causing permanent deformation of the lower items.

Do not use, by any means, steel cables that might easily deform the sheets. They might also cause the collapse of the first panels placed under the pack. Make sure that the slings and the supports cannot move during lifting procedures. Manoeuvres must be performed with caution and gradually.

The sling length must be balanced to ensure balanced lifting and to prevent the sling from causing deformation.

Packs storage on the covering structure must take place only on platforms that can support their weight, in terms of resistance, safety and support conditions, but also taking into account the works being carried out. It is also important to consider the roof gradient. The packs must be fastened well in order to ensure their stability, also in case of sudden weather events.

Packs stored at height must be appropriately fastened to the vehicles (it is advisable to ask the Works Management for a storing authorisation).

Manual handling of single items must be performed by lifting it without dragging it on the one placed under it. It must be rotated on its side next to the pack. Transport must be carried out by at least two people according to its length, keeping the item on its side (see picture on the following page).



INFORMATION REGARDING ASSEMBLY

PRELIMINARY OPERATIONS

Consult the project documents and respect the provisions contained therein.

- a) Assess the alignment of corrugated sheets/panels support structures. Make sure the laying surface is flat.
- b) Check the compatibility of the support surfaces that will come into contact with the corrugated sheets/panels. If this were not the case, protect them against corrosion due to electrochemical effect. This is especially true in case of aluminium sheets or panels on a non-protected metal structure. To receive further information on the compatibility of use of the different metals, consult section A; make sure that there are no interferences with overhead electrical power lines or in the manoeuvring areas of corrugated sheets/panels;
- c) Make sure that the area near the site where materials are applied is free from ferrous dust resulting from diesel combustion as this leads to early corrosion;
- d) The installer must perform all assembly operations in compliance with the safety norms in force;
- e) The staff responsible for application operations must be provided with shoes whose soles don't damage external cladding;
- f) Storing, lifting, handling and storing at height of corrugated sheets/panels must be performed accurately and in compliance with the provisions;
- g) It is important to assess the material during its application (warranty condition);
- h) Should you notice anomalies or protrusions on the product or its finishing during application (especially, aesthetic effects or differences in colour etc.), avoid application in order not to void the warranty. UNIMETAL shall not be held responsible for flaws, visible or apparent, and for the warranty in case the material has already been applied.



COVERING DESIGN ASPECTS

Components

Corrugated sheets or panels are used in both civil and industrial buildings for coverings, walls and roofing. They can be installed on several support structures: metal framing, normal concrete and PSC, wood. When working with corrugated sheets/panels, support structures and fixing devices must be adequately sized and must meet safety, stability and functionality requirements as envisaged by the project. It is advisable to use fixing devices provided by the sheets/panels manufacturer.

Gradient

Products application must take place on sloping roofs whose gradient cannot be lower than 7% regarding corrugated sheets and panels.

Coverings with minimum slope of 5% are possible for Genus 10 Perfect with seal. The covering gradient shall depend on environmental conditions, on the project solutions and on the type of sheets/panels used.

RECOMMENDATIONS FOR THE INSTALLATION OF CORRUGATED SHEETS AND METAL

Regarding cutting procedures performed at the building site, use suitable tools (jigsaw, shears, nibbler, etc.). Do not use tools with abrasive disks. Regarding fixing operations, use screwdrivers with torque limit.

IMMEDIATELY REMOVE ALL RESIDUAL MATERIALS, ESPECIALLY METAL ONES;

HEAD TRANSVERSAL INTERMEDIATE JOINTS STACKING

In case of head stacking, slope must take into account the type of joint and the material used, besides specific environmental conditions.

PANELS LATERAL STACKING

Panels, especially covering ones, must be perfectly stacked in order to prevent condensation build-up.

Standard seal, envisaged for longitudinal joints, has a limited function and cannot ensure holding stability nor it represents a barrier against temperature changes.

In order to improve safety and insulation near the joint, use, during installation, an additional expanded polyethylene seal, which can be provided by the manufacturer on request.

The application of such seal must take place paying utmost attention in order to ensure insulation continuity.



www.unimetal.net

unimetal general catalogue
release 2018

unimetal.net

Headquarters and manufacturing centre

Torre San Giorgio (CN)

Via Circonvallazione G. Giolitti, 21

T. +39 0172 96155 - F. +39 0172 96200

www.unimetal.net

unimetal@unimetal.net

